



Starclassic

 **TAMA**

2021 GENERAL CATALOG  
**DRUMS AND HARDWARE**





# TABLE OF CONTENTS

STAR BUBINGA . . . . .	4
STAR MAPLE . . . . .	6
STAR WALNUT . . . . .	8
STARCLASSIC MAPLE . . . . .	10
STARCLASSIC WALNUT/BIRCH . . . . .	16
STARCLASSIC PERFORMER . . . . .	20
S.L.P. DRUM KITS -STUDIO MAPLE- . . . . .	22
S.L.P. DRUM KITS -FAT SPRUCE- . . . . .	23
S.L.P. DRUM KITS -DYNAMIC KAPUR- . . . . .	24
S.L.P. DRUM KITS -NEW VINTAGE HICKORY- . . . . .	25
SUPERSTAR HYPER-DRIVE DUO . . . . .	26
SUPERSTAR HYPER-DRIVE MAPLE . . . . .	28
SUPERSTAR CLASSIC MAPLE . . . . .	32
IMPERIALSTAR . . . . .	38
RHYTHM MATE . . . . .	40
CLUB-JAM . . . . .	41
CLUB-JAM MINI . . . . .	43
CLUB-JAM SUITCASE . . . . .	44
CLUB-JAM FLYER . . . . .	45
COCKTAIL-JAM . . . . .	46
COCKTAIL-JAM MINI . . . . .	47
SNARE DRUMS . . . . .	48
SIGNATURE PALETTE SNARE DRUMS . . . . .	56
DRUM PEDALS . . . . .	60
HI-HAT STANDS . . . . .	64
DRUM THRONES . . . . .	66
SNARE STANDS . . . . .	68
CYMBAL STANDS . . . . .	70
TOM STANDS & TOM HOLDERS . . . . .	72
HARDWARE KITS . . . . .	74
POWER TOWER SYSTEM . . . . .	75
CLAMPS AND ATTACHMENTS . . . . .	76
MICROPHONE STANDS . . . . .	79
TAMA PERCUSSION . . . . .	81
PRACTICE TOOLS . . . . .	82
BAGS . . . . .	83
ACCESSORIES . . . . .	86
DRUM STICKS . . . . .	94
MARCHING PERCUSSION . . . . .	98
CONCERT PERCUSSION . . . . .	105

# STAR BUBINGA

## Lacquer Finishes

STAR is the flagship line for TAMA drums. It takes the knowledge and research we cultivated for the Starclassic series to the next level, by reexamining every detail to enhance shell resonance. STAR Bubinga features a thin 5mm shell. Every shell comes equipped with 9mm thick Sound Focus Rings (SFR) for structural support. This shell configuration provides clear projection and resonance to highlight the distinct sound of Bubinga.

**NEW**



**COLOR** Sunset Australian Acacia Burst **SAC**

including:  
22"x16" bass drum  
8"x6" tom tom  
10"x7" tom tom  
12"x8" tom tom  
14"x14" floor tom  
16"x16" floor tom  
14"x6.5" snare drum



**COLOR** Solid Candy Red **SDR**

including:  
20"x16" bass drum  
8"x7" tom tom  
10"x7" tom tom  
12"x7" tom tom  
13"x7.5" tom tom  
14"x12" floor tom  
16"x14" floor tom  
14"x6.5" snare drum

# INDIVIDUAL MODEL NUMBERS

Diameter	Depth	Model No.
<b>Bass Drums</b>		
16"	12"	TBB1612S
18"	14"	TBB1814S
18"	15"	TBB1815S
18"	16"	TBB1816S
20"	14"	TBB2014S
20"	16"	TBB2016S
20"	17"	TBB2017S
20"	18"	TBB2018S
22"	14"	TBB2214S
22"	16"	TBB2216S
22"	17"	TBB2217S
22"	18"	TBB2218S
24"	14"	TBB2414S
24"	16"	TBB2416S
24"	17"	TBB2417S
24"	18"	TBB2418S
26"	14"	TBB2614S
26"	16"	TBB2616S
<b>Floor Toms</b>		
13"	12"	TBF1312S
14"	12"	TBF1412S
14"	13"	TBF1413S
14"	14"	TBF1414S
15"	13"	TBF1513S
15"	14"	TBF1514S
15"	15"	TBF1515S
16"	14"	TBF1614S
16"	15"	TBF1615S
16"	16"	TBF1616S
18"	14"	TBF1814S
18"	15"	TBF1815S
18"	16"	TBF1816S

\*Please ask price for "outside & inside inlay" option.

Diameter	Depth	Model No.
<b>Tom Toms</b>		
8"	6"	TBT0806S
8"	7"	TBT0807S
8"	8"	TBT0808S
10"	6.5"	TBT1065S
10"	7"	TBT1007S
10"	8"	TBT1008S
10"	9"	TBT1009S
10"	10"	TBT1010S
12"	7"	TBT1207S
12"	8"	TBT1208S
12"	9"	TBT1209S
12"	10"	TBT1210S
12"	11"	TBT1211S
13"	7.5"	TBT1375S
13"	9"	TBT1309S
13"	10"	TBT1310S
13"	11"	TBT1311S
13"	12"	TBT1312S
14"	8"	TBT1408S
14"	10"	TBT1410S
14"	11"	TBT1411S
14"	12"	TBT1412S
14"	13"	TBT1413S
<b>Snare Drums</b>		
13"	6"	TBS136S
14"	5.5"	TBS1455S
14"	6.5"	TBS1465S
14"	8"	TBS148S

## SPECIFICATIONS

### Shells

5mm, 5ply Bubinga + 1 inner ply Cordia w/ 9mm Sound Focus Rings  
 (LNTI) 5mm, 4ply Bubinga + 1 outer ply Indian Laurel + 1 inner ply Cordia w/ 9mm Sound Focus Rings  
 (CDKG/CDKR) 5mm, 4ply Bubinga + 1 outer & 1 inner ply Cordia w/ 9mm Sound Focus Rings  
 (SAC) 5mm, 4mm Bubinga + 1 outer ply Australian Acacia+ 1 inner ply Cordia w/9mm Sound Focus Ring

### STAR Bearing Edges

### Super Resonant Mounting System

### Quick-Lock Tom Brackets

### Minimum Shell Contact

### STAR Floor Tom Legs

### Hold Tight™ Washers

### Remo® Drum Heads

## MODEL NUMBER SYSTEM - Individual Drums

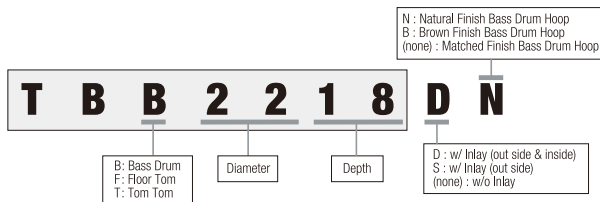

## FINISHES (Lacquer)



Sunset Australian Acacia Burst  
SAC



Dark Green Cordia  
CDKG



Dark Red Cordia  
CDKR



Natural Indian Laurel  
LNTI



Dark Burgundy Metallic  
DBM



Satin Blue Metallic  
SBM



Antique White  
ATW

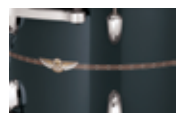

Smoky Black  
SKB



Atomic Orange  
AMO



Grand Aqua Blue  
GAQ



Grand Royal Blue  
GYB



Solid Candy Red  
SDR



Piano Black  
PBK



Sunny Yellow Lacquer  
SYL



Vintage Sea Blue  
VSB

# STAR MAPLE

## Lacquer Finishes

STAR is the flagship line for TAMA drums. It takes the knowledge and research we cultivated for the Starclassic series to the next level, by reexamining every detail to enhance shell resonance. STAR Maple shell's "Solid Core Ply" is a totally new design for this series. This unique shell provides the warm, open tone of Maple, combined with the rich, hearty sound of a solid ply shell.

**NEW**



**COLOR** Emerald Sea Curly Maple Burst **RECB**

including:  
22"x16" bass drum  
8"x6" tom tom  
10"x7" tom tom  
12"x8" tom tom  
14"x14" floor tom  
16"x16" floor tom  
14"x6.5" snare drum



**COLOR** Gloss Natural Curly Maple **RGCM**

including:  
22"x16" bass drum  
8"x6" tom tom  
10"x7" tom tom  
12"x8" tom tom  
14"x14" floor tom  
16"x16" floor tom  
14"x6.5" snare drum

# INDIVIDUAL MODEL NUMBERS

Diameter	Depth	Model No.
<b>Bass Drums</b>		
16"	12"	TMB1612S
18"	14"	TMB1814S
18"	15"	TMB1815S
18"	16"	TMB1816S
20"	14"	TMB2014S
20"	16"	TMB2016S
20"	17"	TMB2017S
20"	18"	TMB2018S
22"	14"	TMB2214S
22"	16"	TMB2216S
22"	17"	TMB2217S
22"	18"	TMB2218S
24"	14"	TMB2414S
24"	16"	TMB2416S
24"	17"	TMB2417S
24"	18"	TMB2418S
26"	14"	TMB2614S
26"	16"	TMB2616S
<b>Floor Toms</b>		
13"	12"	TMF1312S
14"	12"	TMF1412S
14"	13"	TMF1413S
14"	14"	TMF1414S
15"	13"	TMF1513S
15"	14"	TMF1514S
15"	15"	TMF1515S
16"	14"	TMF1614S
16"	15"	TMF1615S
16"	16"	TMF1616S
18"	14"	TMF1814S
18"	15"	TMF1815S
18"	16"	TMF1816S

Diameter	Depth	Model No.
<b>Tom Toms</b>		
8"	6"	TMT0806S
8"	7"	TMT0807S
8"	8"	TMT0808S
10"	6.5"	TMT1065S
10"	7"	TMT1007S
10"	8"	TMT1008S
10"	9"	TMT1009S
10"	10"	TMT1010S
12"	7"	TMT1207S
12"	8"	TMT1208S
12"	9"	TMT1209S
12"	10"	TMT1210S
12"	11"	TMT1211S
13"	7.5"	TMT1375S
13"	9"	TMT1309S
13"	10"	TMT1310S
13"	11"	TMT1311S
13"	12"	TMT1312S
14"	8"	TMT1408S
14"	10"	TMT1410S
14"	11"	TMT1411S
14"	12"	TMT1412S
14"	13"	TMT1413S
<b>Snare Drums</b>		
13"	6"	TMS136S
14"	5.5"	TMS1455S
14"	6.5"	TMS1465S
14"	8"	TMS148S

\*Please ask price for "outside & inside inlay" option.

## MODEL NUMBER SYSTEM - Individual Drums

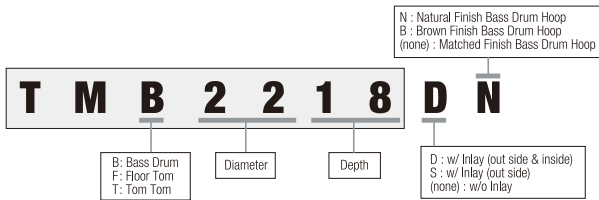

## SPECIFICATIONS

### Shells

5mm, 5ply Maple w/ 5mm Sound Focus Rings  
(RGCM/ROLC/RRCM/RECB) 5mm, 5ply Maple +1 outer ply Curly Maple w/ 5mm Sound Focus Rings

STAR Bearing Edges  
Super Resonant Mounting System  
Quick-Lock Tom Brackets  
Minimum Shell Contact  
STAR Floor Tom Legs  
Hold Tight™ Washers  
Remo® Drum Heads

## FINISHES (Lacquer)

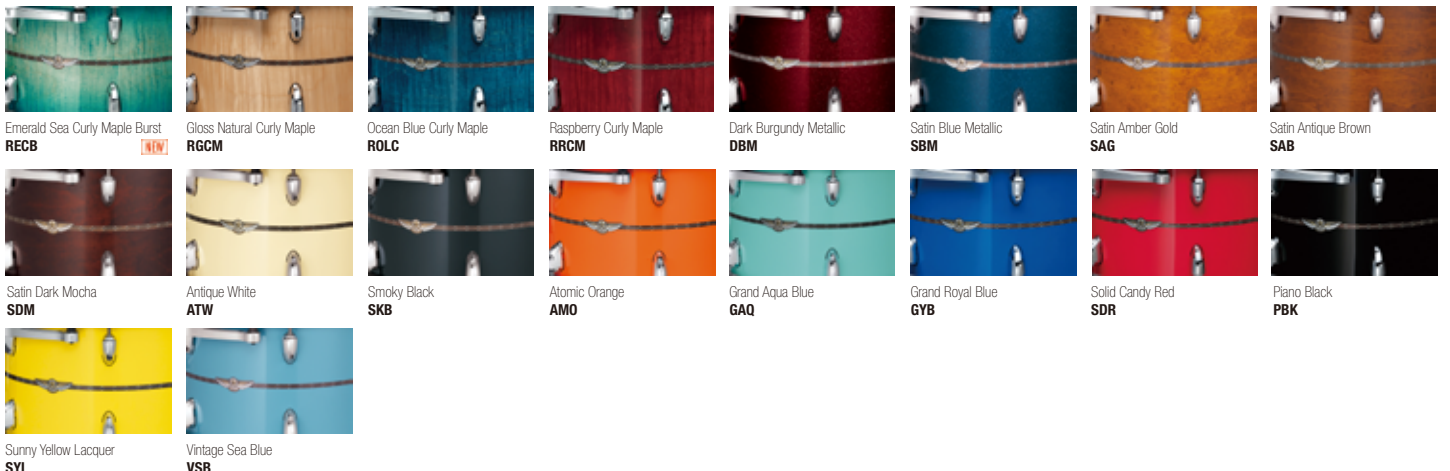

# STAR WALNUT

## Lacquer Finishes

STAR is the flagship line for TAMA drums. It takes the knowledge and research we cultivated for the Starclassic series to the next level, by reexamining every detail to enhance shell resonance. Walnut has long been favored by furniture makers for both its beauty and durability. As a drum shell material, Walnut's naturally EQ'ed tone has been praised by the drum community for both the stage and the studio. The STAR Walnut shells project booming low end with enough cut to be heard through any mix.

**NEW**

**COLOR** Roasted Japanese Chestnut **RSC**

### TW42RZS basic kit

including:  
22"x16" bass drum  
10"x7" tom tom  
12"x8" tom tom  
16"x16" floor tom  
[add-on]  
14"x6.5" snare drum



## KIT CONFIGURATIONS LIST

[22"BD 4pc Shell Kit]

TW42RZS

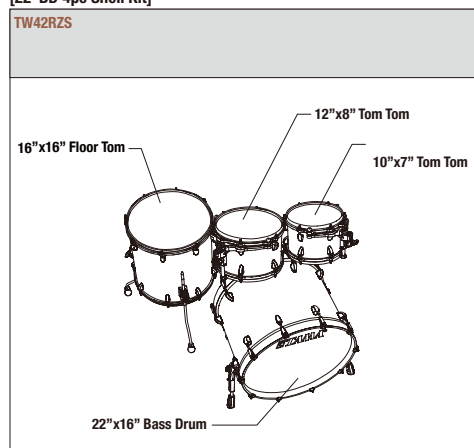

Flo Dauner | Die Fantastischen Vier



# INDIVIDUAL MODEL NUMBERS

Diameter	Depth	Model No.
<b>Bass Drums</b>		
16"	12"	TWB1612
18"	14"	TWB1814
18"	15"	TWB1815
18"	16"	TWB1816
20"	14"	TWB2014
20"	16"	TWB2016
20"	17"	TWB2017
20"	18"	TWB2018
22"	14"	TWB2214
22"	16"	TWB2216
22"	17"	TWB2217
22"	18"	TWB2218
24"	14"	TWB2414
24"	16"	TWB2416
24"	17"	TWB2417
24"	18"	TWB2418
26"	14"	TWB2614
26"	16"	TWB2616
<b>Floor Toms</b>		
13"	12"	TWF1312
14"	12"	TWF1412
14"	13"	TWF1413
14"	14"	TWF1414
15"	13"	TWF1513
15"	14"	TWF1514
15"	15"	TWF1515
16"	14"	TWF1614
16"	15"	TWF1615
16"	16"	TWF1616
18"	14"	TWF1814
18"	15"	TWF1815
18"	16"	TWF1816

Diameter	Depth	Model No.
<b>Tom Toms</b>		
8"	6"	TWT0806
8"	7"	TWT0807
8"	8"	TWT0808
10"	6.5"	TWT1065
10"	7"	TWT1007
10"	8"	TWT1008
10"	9"	TWT1009
10"	10"	TWT1010
12"	7"	TWT1207
12"	8"	TWT1208
12"	9"	TWT1209
12"	10"	TWT1210
12"	11"	TWT1211
13"	7.5"	TWT1375
13"	9"	TWT1309
13"	10"	TWT1310
13"	11"	TWT1311
13"	12"	TWT1312
14"	8"	TWT1408
14"	10"	TWT1410
14"	11"	TWT1411
14"	12"	TWT1412
14"	13"	TWT1413
<b>Snare Drums</b>		
13"	6"	TWS136
14"	5.5"	TWS1455
14"	6.5"	TWS1465
14"	8"	TWS148

## SPECIFICATIONS

### Shells

All Walnut Shell TT/FT/SD: 6mm 6ply, BD: 7mm 7ply  
 (AUB/AGJB/ASBJ/ASCS)TT/FT/SD: 6mm, 4ply Walnut + 2 outer ply Japanese Sen  
 BD: 7mm, 5ply Walnut + 2 outer ply Japanese Sen  
 (LIC/CJC/RSC) TT/FT/SD: 6mm, 5ply Walnut + 1 outer ply Japanese Chestnut  
 BD: 7mm, 6ply Walnut + 1 outer ply Japanese Chestnut

STAR Bearing Edges  
 Super Resonant Mounting System  
 Quick-Lock Tom Brackets  
 Minimum Shell Contact  
 STAR Floor Tom Legs  
 Hold Tight™ Washers  
 Remo® Drum Heads

### MODEL NUMBER SYSTEM - Individual Drums

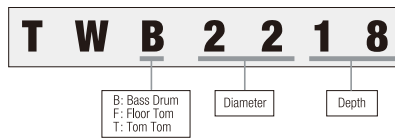

## FINISHES (Lacquer)

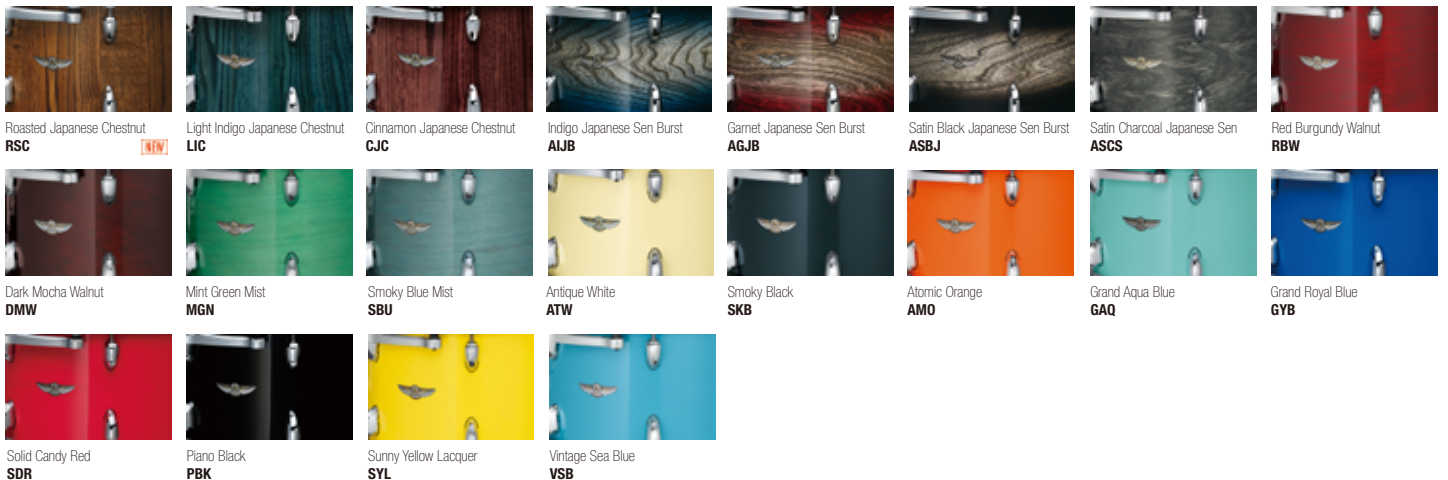

# STARCLASSIC MAPLE

## Exotic Finishes

In the '80s TAMA's Superstars and Imperialstars reigned supreme - the perfect drums for the times. But TAMA's builders and designers wanted something that transcended trends, something timeless - drums that understood a player's passion and allowed the expression of every genre, style, mood, and technique. They created Starclassic Maple drums...and ignited the thin-shell revolution. And now the Exotic Finish line offers beautiful, one-of-a-kind exotic wood exteriors for that extra luxurious touch.

Numerous options are available to meet the varied and critical needs of professional drummers including a selection of more than 30 different shell sizes. Starclassic Maple also features three shell hardware finishes to choose from: Black Nickel, Chrome and Smoked Black Nickel. Starclassic Maple is simply an unprecedented combination of sight and sound.



**COLOR** Tobacco Sunburst Movingui **VTBV**  
w/ smoked black nickel hardware

### ME42TZUS basic kit

including:  
22"x16" bass drum  
10"x7" tom tom  
12"x8" tom tom  
16"x16" floor tom

[add-on]  
14"x6.5" snare drum

## KIT CONFIGURATIONS LIST

### [20"BD 3pc Shell Kit]

ME30CMS w/ Chrome Hardware  
ME30CMBS w/ Black Nickel Hardware  
ME30CMUS w/ Smoked Black Nickel Hardware

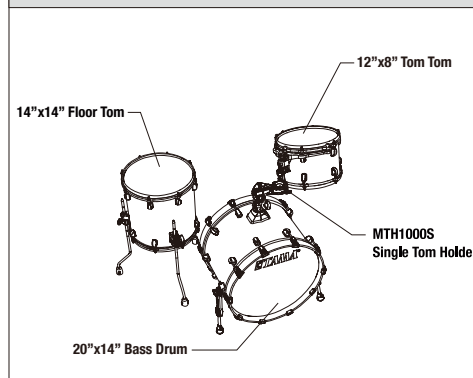

### [22"BD 3pc Shell Kit]

ME32CZS w/ Chrome Hardware  
ME32CZBS w/ Black Nickel Hardware  
ME32CZUS w/ Smoked Black Nickel Hardware

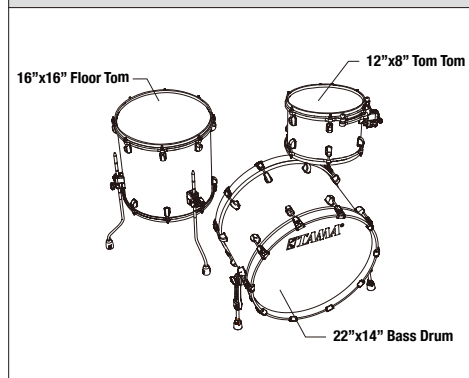

### [22"BD 4pc Shell Kit]

ME42TZS w/ Chrome Hardware  
ME42TZBS w/ Black Nickel Hardware  
ME42TZUS w/ Smoked Black Nickel Hardware

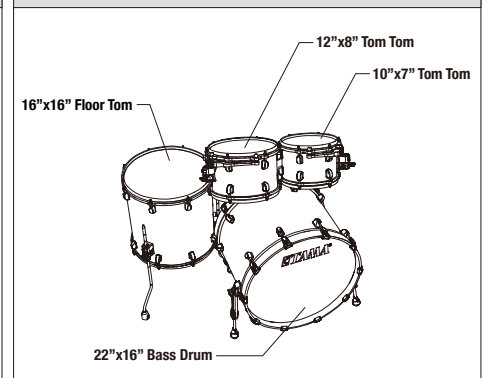

# INDIVIDUAL MODEL NUMBERS

Diameter	Depth	Model No.		
		Black Nickel	Chrome	Smoked Black Nickel
<b>Bass Drums</b>				
16"	12"	MEB1612ZB	MEB1612Z	MEB1612ZU
18"	14"	MEB1814ZB	MEB1814Z	MEB1814ZU
18"	16"	MEB1816ZB	MEB1816Z	MEB1816ZU
20"	14"	MEB2014ZB	MEB2014Z	MEB2014ZU
20"	16"	MEB2016ZB	MEB2016Z	MEB2016ZU
20"	18"	MEB2018ZB	MEB2018Z	MEB2018ZU
22"	14"	MEB2214ZB	MEB2214Z	MEB2214ZU
22"	16"	MEB2216ZB	MEB2216Z	MEB2216ZU
22"	18"	MEB2218ZB	MEB2218Z	MEB2218ZU
22"	20"	MEB2220ZB	MEB2220Z	MEB2220ZU
24"	14"	MEB2414ZB	MEB2414Z	MEB2414ZU
24"	16"	MEB2416ZB	MEB2416Z	MEB2416ZU
24"	18"	MEB2418ZB	MEB2418Z	MEB2418ZU
<b>Floor Toms</b>				
13"	12"	MEF1312B	MEF1312	MEF1312U
14"	12"	MEF1412B	MEF1412	MEF1412U
14"	14"	MEF1414B	MEF1414	MEF1414U
16"	14"	MEF1614B	MEF1614	MEF1614U
16"	16"	MEF1616B	MEF1616	MEF1616U
18"	16"	MEF1816B	MEF1816	MEF1816U
<b>Tom Toms</b>				
8"	6"	MET0806B	MET0806	MET0806U
8"	7"	MET0807B	MET0807	MET0807U
8"	8"	MET0808B	MET0808	MET0808U
10"	6.5"	MET1065B	MET1065	MET1065U
10"	7"	MET1007B	MET1007	MET1007U
10"	8"	MET1008B	MET1008	MET1008U
10"	9"	MET1009B	MET1009	MET1009U
12"	7"	MET1207B	MET1207	MET1207U
12"	8"	MET1208B	MET1208	MET1208U
12"	9"	MET1209B	MET1209	MET1209U
12"	10"	MET1210B	MET1210	MET1210U
13"	7.5"	MET1375B	MET1375	MET1375U
13"	9"	MET1309B	MET1309	MET1309U
13"	10"	MET1310B	MET1310	MET1310U
13"	11"	MET1311B	MET1311	MET1311U
14"	10"	MET1410B	MET1410	MET1410U
14"	11"	MET1411B	MET1411	MET1411U
14"	12"	MET1412B	MET1412	MET1412U
16"	13"	MET1613B	MET1613	MET1613U
16"	14"	MET1614B	MET1614	MET1614U
<b>Snare Drums</b>				
13"	6"	MES136B	MES136	MES136U
14"	5.5"	MES1455B	MES1455	MES1455U
14"	6.5"	MES1465B	MES1465	MES1465U
14"	8"	MES148B	MES148	MES148U

# SPECIFICATIONS

## Shells

(LEWB/LNWB/LRWB)  
 TT/FT: 5mm 6ply Maple + 1 outer ply Pacific Walnut  
 BD/SD: 7mm 8ply Maple + 1 outer ply Pacific Walnut

(VGLM/VOLM/VVLM/VTBV)  
 TT/FT: 5mm 6ply Maple + 1 outer ply Movingui  
 BD/SD: 7mm 8ply Maple + 1 outer ply Movingui

- Star-Cast Mounting System
- Quick-Lock Tom Bracket
- EVANS® Heads
- Die-Cast Hoops
- Hold Tight™ Washers
- Claw Hooks w/ Rubber Spacers
- Cushioned Floor Tom Legs

# OPTION



Chrome HW      Black Nickel HW      Smoked Black Nickel HW

## MODEL NUMBER SYSTEM - Individual Drums

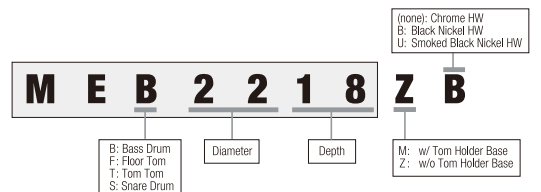

WOLFRAM KELLNER | J.B.O.

# FINISHES (Lacquer)



# STARCLASSIC MAPLE

Lacquer Finishes



**COLOR** Molten Electric Blue Burst **MEB**  
w/ black nickel hardware

## MA42TZBNS basic kit

including:  
22"x16" bass drum  
10"x7" tom tom  
12"x8" tom tom  
16"x16" floor tom

[add-on]  
14"x6.5" snare drum

## KIT CONFIGURATIONS LIST

### [20"BD 3pc Shell Kit]

MA30CMS w/ Chrome Hardware  
MA30CBNS w/ Black Nickel Hardware  
MA30CMUS w/ Smoked Black Nickel Hardware

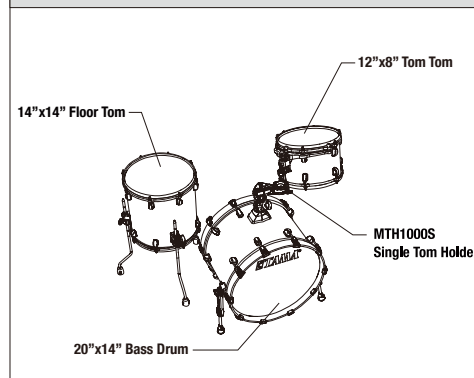

### [22"BD 3pc Shell Kit]

MA32CZS w/ Chrome Hardware  
MA32CBNS w/ Black Nickel Hardware  
MA32CZUS w/ Smoked Black Nickel Hardware

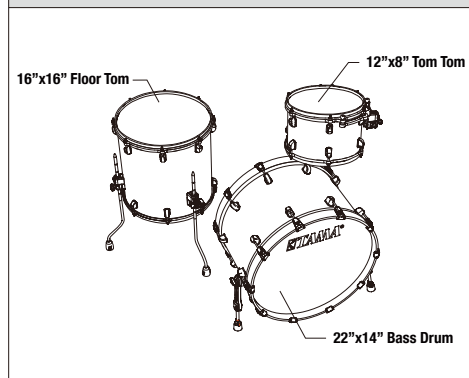

### [22"BD 4pc Shell Kit]

MA42ZS w/ Chrome Hardware  
MA42ZBNS w/ Black Nickel Hardware  
MA42ZUS w/ Smoked Black Nickel Hardware

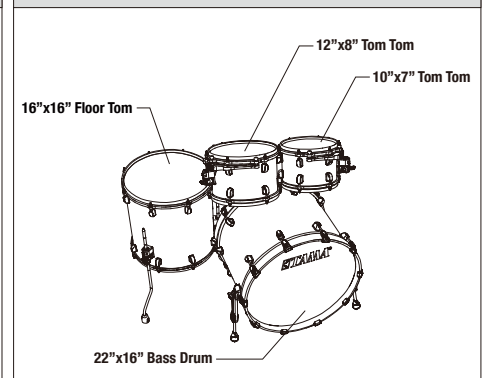

# INDIVIDUAL MODEL NUMBERS

Diameter	Depth	Model No.		
		Black Nickel	Chrome	Smoked Black Nickel
<b>Bass Drum</b> *To order Bass Drum w/ Tom Holder Base, Please substitute "Z" with "M". Ex MAB2218Z → MAB2218M				
16"	12"	MAB1612ZBN	MAB1612Z	MAB1612ZU
18"	14"	MAB1814ZBN	MAB1814Z	MAB1814ZU
18"	16"	MAB1816ZBN	MAB1816Z	MAB1816ZU
20"	14"	MAB2014ZBN	MAB2014Z	MAB2014ZU
20"	16"	MAB2016ZBN	MAB2016Z	MAB2016ZU
20"	18"	MAB2018ZBN	MAB2018Z	MAB2018ZU
22"	14"	MAB2214ZBN	MAB2214Z	MAB2214ZU
22"	16"	MAB2216ZBN	MAB2216Z	MAB2216ZU
22"	18"	MAB2218ZBN	MAB2218Z	MAB2218ZU
22"	20"	MAB2220ZBN	MAB2220Z	MAB2220ZU
24"	14"	MAB2414ZBN	MAB2414Z	MAB2414ZU
24"	16"	MAB2416ZBN	MAB2416Z	MAB2416ZU
24"	18"	MAB2418ZBN	MAB2418Z	MAB2418ZU
<b>Floor Toms</b>				
13"	12"	MAF1312BN	MAF1312	MAF1312U
14"	12"	MAF1412BN	MAF1412	MAF1412U
14"	14"	MAF1414BN	MAF1414	MAF1414U
16"	14"	MAF1614BN	MAF1614	MAF1614U
16"	16"	MAF1616BN	MAF1616	MAF1616U
18"	16"	MAF1816BN	MAF1816	MAF1816U
<b>Tom Toms</b>				
8"	6"	MAT0806BN	MAT0806	MAT0806U
8"	7"	MAT0807BN	MAT0807	MAT0807U
8"	8"	MAT0808BN	MAT0808	MAT0808U
10"	6.5"	MAT1065BN	MAT1065	MAT1065U
10"	7"	MAT1007BN	MAT1007	MAT1007U
10"	8"	MAT1008BN	MAT1008	MAT1008U
10"	9"	MAT1009BN	MAT1009	MAT1009U
12"	7"	MAT1207BN	MAT1207	MAT1207U
12"	8"	MAT1208BN	MAT1208	MAT1208U
12"	9"	MAT1209BN	MAT1209	MAT1209U
12"	10"	MAT1210BN	MAT1210	MAT1210U
13"	7.5"	MAT1375BN	MAT1375	MAT1375U
13"	9"	MAT1309BN	MAT1309	MAT1309U
13"	10"	MAT1310BN	MAT1310	MAT1310U
13"	11"	MAT1311BN	MAT1311	MAT1311U
14"	10"	MAT1410BN	MAT1410	MAT1410U
14"	11"	MAT1411BN	MAT1411	MAT1411U
14"	12"	MAT1412BN	MAT1412	MAT1412U
16"	13"	MAT1613BN	MAT1613	MAT1613U
16"	14"	MAT1614BN	MAT1614	MAT1614U
<b>Snare Drums</b>				
13"	6"	MAS136BN	MAS136	MAS136U
14"	5.5"	MAS1455BN	MAS1455	MAS1455U
14"	6.5"	MAS1465BN	MAS1465	MAS1465U
14"	8"	MAS148BN	MAS148	MAS148U

# SPECIFICATIONS

## Shells

All Maple Shell  
TT/FT: 5mm 6ply  
BD/SD: 7mm 8ply

## Star-Cast Mounting System

- Quick-Lock Tom Bracket
- EVANS® Heads
- Die-Cast Hoops
- Hold Tight™ Washers
- Claw Hooks w/ Rubber Spacers
- Cushioned Floor Tom Legs

# OPTION



Chrome HW



Black Nickel HW



Smoked Black Nickel HW

## MODEL NUMBER SYSTEM - Individual Drums

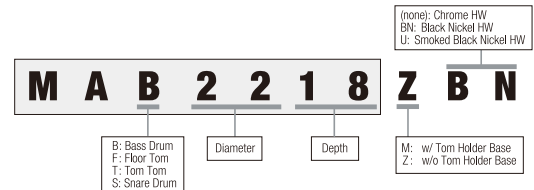

# FINISHES (Lacquer)

Champagne Sparkle <b>CHS</b>	Deeper Purple <b>DPP</b>	Galaxy Chameleon Sparkle <b>GCS</b>	Black Clouds & Silver Linings <b>BCS</b>	Light Jade Burst <b>LJB</b>	Flat Deep Green Metallic <b>FDG</b>	Flat Steel Blue Metallic <b>FLM</b>	Satin Aztec Gold Metallic <b>SAM</b>	Dark Mocha Burst <b>DMB</b>
Flat Black <b>FBK</b>	Flat Burgundy Metallic <b>FBM</b>	Molten Electric Blue Burst <b>MEB</b>	Molten Satin Brown Burst <b>MBB</b>	Vintage Antique Maple <b>VAM</b>	Silver Snow Racing Stripe <b>SSR</b>	Piano White <b>PWH</b>	Piano Black <b>PBK</b>	

# STARCLASSIC MAPLE

Duracover Wrap Finishes

**NEW**



**COLOR** Surf Green Silk  
w/ smoked black nickel hardware

**SGS**

**MR42TZUS basic kit**

including:  
22"x16" bass drum  
10"x7" tom tom  
12"x8" tom tom  
16"x16" floor tom

[add-on]  
14"x6.5" snare drum

## KIT CONFIGURATIONS LIST

**[20"BD 3pc Shell Kit]**

MR30CMS w/ Chrome Hardware  
MR30CMBNS w/ Black Nickel Hardware  
MR30CMUS w/ Smoked Black Nickel Hardware

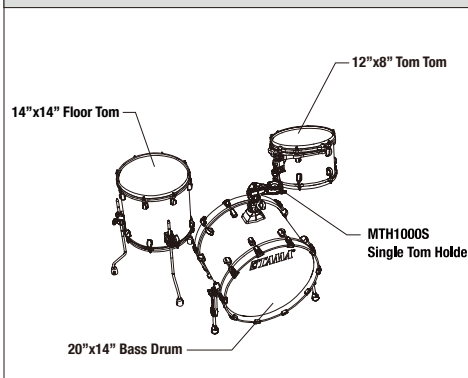

**[22"BD 3pc Shell Kit]**

MR32CZS w/ Chrome Hardware  
MR32CZBNS w/ Black Nickel Hardware  
MR32CZUS w/ Smoked Black Nickel Hardware

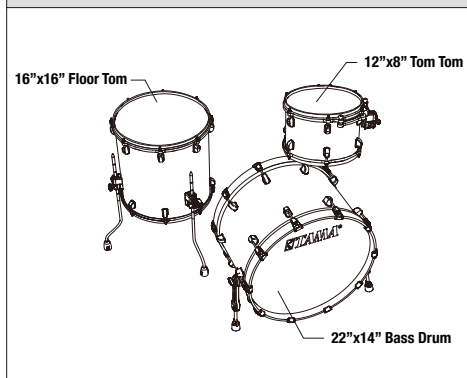

**[22"BD 4pc Shell Kit]**

MR42TZS w/ Chrome Hardware  
MR42TZBNS w/ Black Nickel Hardware  
MR42TZUS w/ Smoked Black Nickel Hardware

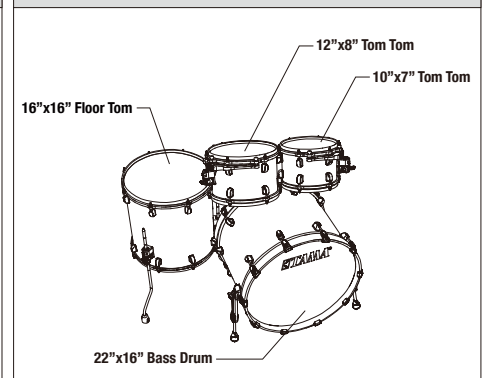

# INDIVIDUAL MODEL NUMBERS

Diameter	Depth	Model No.		
		Black Nickel	Chrome	Smoked Black Nickel
<b>Bass Drum</b> *To order Bass Drum w/ Tom Holder Base, Please substitute "Z" with "M". Ex MRB2218Z → MRB2218M				
16"	12"	MRB1612ZBN	MRB1612Z	MRB1612ZU
18"	14"	MRB1814ZBN	MRB1814Z	MRB1814ZU
18"	16"	MRB1816ZBN	MRB1816Z	MRB1816ZU
20"	14"	MRB2014ZBN	MRB2014Z	MRB2014ZU
20"	16"	MRB2016ZBN	MRB2016Z	MRB2016ZU
20"	18"	MRB2018ZBN	MRB2018Z	MRB2018ZU
22"	14"	MRB2214ZBN	MRB2214Z	MRB2214ZU
22"	16"	MRB2216ZBN	MRB2216Z	MRB2216ZU
22"	18"	MRB2218ZBN	MRB2218Z	MRB2218ZU
22"	20"	MRB2220ZBN	MRB2220Z	MRB2220ZU
24"	14"	MRB2414ZBN	MRB2414Z	MRB2414ZU
24"	16"	MRB2416ZBN	MRB2416Z	MRB2416ZU
24"	18"	MRB2418ZBN	MRB2418Z	MRB2418ZU
<b>Floor Toms</b>				
13"	12"	MRF1312BN	MRF1312	MRF1312U
14"	12"	MRF1412BN	MRF1412	MRF1412U
14"	14"	MRF1414BN	MRF1414	MRF1414U
16"	14"	MRF1614BN	MRF1614	MRF1614U
16"	16"	MRF1616BN	MRF1616	MRF1616U
18"	16"	MRF1816BN	MRF1816	MRF1816U
<b>Tom Toms</b>				
8"	6"	MRT0806BN	MRT0806	MRT0806U
8"	7"	MRT0807BN	MRT0807	MRT0807U
8"	8"	MRT0808BN	MRT0808	MRT0808U
10"	6.5"	MRT1065BN	MRT1065	MRT1065U
10"	7"	MRT1007BN	MRT1007	MRT1007U
10"	8"	MRT1008BN	MRT1008	MRT1008U
10"	9"	MRT1009BN	MRT1009	MRT1009U
12"	7"	MRT1207BN	MRT1207	MRT1207U
12"	8"	MRT1208BN	MRT1208	MRT1208U
12"	9"	MRT1209BN	MRT1209	MRT1209U
12"	10"	MRT1210BN	MRT1210	MRT1210U
13"	7.5"	MRT1375BN	MRT1375	MRT1375U
13"	9"	MRT1309BN	MRT1309	MRT1309U
13"	10"	MRT1310BN	MRT1310	MRT1310U
13"	11"	MRT1311BN	MRT1311	MRT1311U
14"	10"	MRT1410BN	MRT1410	MRT1410U
14"	11"	MRT1411BN	MRT1411	MRT1411U
14"	12"	MRT1412BN	MRT1412	MRT1412U
16"	13"	MRT1613BN	MRT1613	MRT1613U
16"	14"	NMRT1614BN	MRT1614	MRT1614U
<b>Snare Drums</b>				
13"	6"	MRS136BN	MRS136	MRS136U
14"	5.5"	MRS1455BN	MRS1455	MRS1455U
14"	6.5"	MRS1465BN	MRS1465	MRS1465U
14"	8"	MRS148BN	MRS148	MRS148U

# SPECIFICATIONS

## Shells

All Maple Shell  
TT/FT: 5mm 6ply  
BD/SD: 7mm 8ply

Star-Cast Mounting System  
Quick-Lock Tom Bracket  
EVANS® Heads  
Die-Cast Hoops  
Hold Tight™ Washers  
Claw Hooks w/ Rubber Spacers  
Cushioned Floor Tom Legs

# OPTION

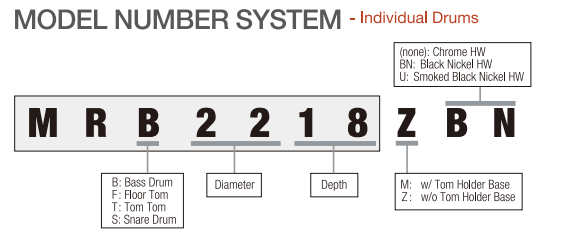

# FINISHES (Duracover Wrap)

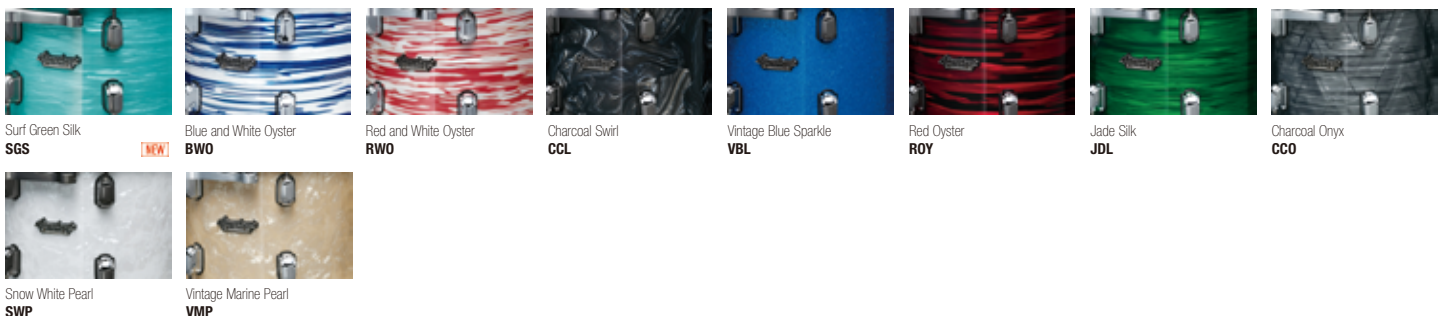

# STARCLASSIC WALNUT/BIRCH

## Lacquer Finishes

Exploring limitless possibilities, our result in the wake of countless experimentation came in the form of the Hybrid Shell Walnut/Birch: combining the superior quality warmth and mid to low frequency tone of the increasingly popular and truly unique Walnut, with the well-defined and uncompromisingly solid attack of Birch. Whilst we successfully preserved their unique sonic trademarks, the characteristics of both Walnut and Birch blend to persuade a very focused sound that would define itself with great distinction within a musical ensemble; married with controlled sustain and clarity; all sealed with an undeniably palpable feeling of warmth and resonance when performed.

**NEW**



**COLOR** Lacquer Shamrock Oyster **LSO**

### WBS52RZS basic kit

including:  
 22"x16" bass drum  
 10"x7" tom tom  
 12"x8" tom tom  
 14"x12" floor tom  
 16"x14" floor tom  
 MC69 single tom attachments (x2)  
 [add-on]  
 14"x6.5" snare drum

#### [20"BD 3pc Shell Kit]

WBS30RS w/ Chrome Hardware

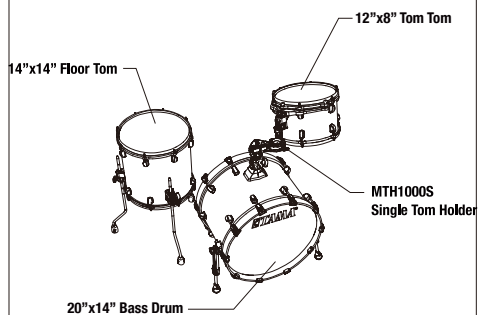

#### [22"BD 3pc Shell Kit]

WBS32RZS w/ Chrome Hardware

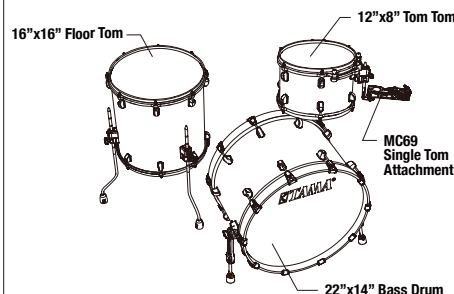

#### [22"BD 4pc Shell Kit]

WBS42S w/ Chrome Hardware

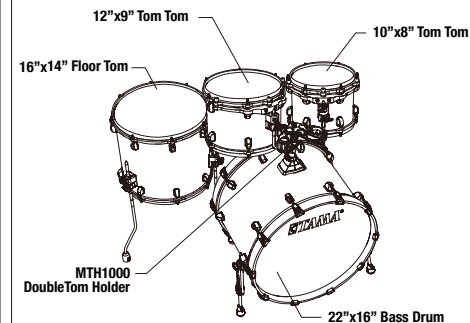

#### [22"BD 5pc Shell Kit]

WBS52RZS w/ Chrome Hardware

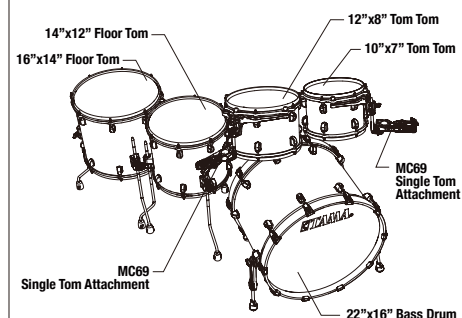

Dariusz "Daray" Brzozowski | Dimmu Borgir



# INDIVIDUAL MODEL NUMBERS

Diameter	Depth	Model No.
<b>Bass Drums</b> *To order Bass Drum w/ Tom Holder Base, Please substitute "Z" with "M". Ex WBSB22DZ → WBSB22DM		
16"	12"	WBSB16HZ
18"	14"	WBSB18RZ
20"	14"	WBSB20RZ
20"	16"	WBSB20DZ
20"	18"	WBSB20EZ
22"	14"	WBSB22RZ
22"	16"	WBSB22DZ
22"	18"	WBSB22EZ
22"	20"	WBSB22XZ
24"	16"	WBSB24DZ
24"	18"	WBSB24EZ
<b>Floor Toms</b>		
13"	12"	WBSF13R
14"	12"	WBSF14A
14"	14"	WBSF14D
16"	14"	WBSF16A
16"	16"	WBSF16D
18"	16"	WBSF18D
<b>Tom Toms</b>		
8"	6"	WBST8H
8"	7"	WBST8A
10"	6.5"	WBST10H
10"	7"	WBST10R
10"	8"	WBST10A
12"	7"	WBST12H
12"	8"	WBST12R
12"	9"	WBST12A
13"	7.5"	WBST13H
13"	9"	WBST13R
13"	10"	WBST13A
14"	11"	WBST14A
14"	12"	WBST14D
16"	13"	WBST16A
16"	14"	WBST16D
<b>Snare Drums</b>		
13"	6"	WBSS136
14"	5.5"	WBSS55
14"	6.5"	WBSS65
14"	8"	WBSS148

## MODEL NUMBER SYSTEM - Individual Drums

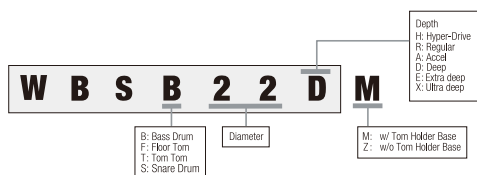

## SPECIFICATIONS

### Shells

TT/FT/SD: 6mm 4ply European Birch + 2 inner ply American Black Walnut  
 BD: 8mm 5ply European Birch + 2 inner ply American Black Walnut

Star-Cast Mounting System

Quick-Lock Tom Bracket

EVANS® Heads

Claw Hooks w/ Rubber Sappers

Cushioned Floor Tom Legs

Die-Cast Hoops

## FINISHES (Lacquer)



Lacquer Shamrock Oyster  
LSO



Lacquer Ocean Blue Ripple  
LOR



Lacquer Phantasm Oyster  
LPO



Satin Purple Atmosphere Fade  
SAF



Satin Burgundy Fade  
SGF



Satin Sapphire Fade  
SPF



Transparent Mocha Fade  
TMF



Molten Brown Burst  
MBR



Piano Black  
PBK

# STARCLASSIC WALNUT/BIRCH

Duracover Wrap Finishes

**NEW**



**COLOR** Surf Green Silk

**SGS**

## WBR32RZS basic kit

including:

- 22"x14" bass drum
- 12"x8" tom tom
- 16"x16" floor tom
- MC69 single tom attachment

[add-on]

- 14"x6.5" snare drum

## KIT CONFIGURATIONS LIST

### [20"BD 3pc Shell Kit]

WBR30RS w/ Chrome Hardware

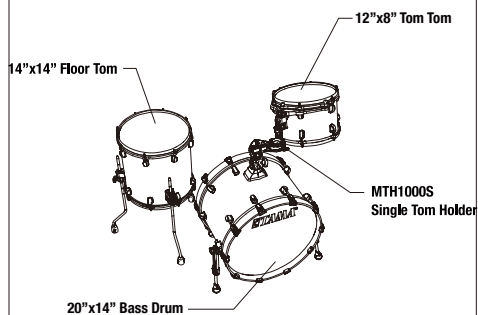

### [22"BD 3pc Shell Kit]

WBR32RZS w/ Chrome Hardware

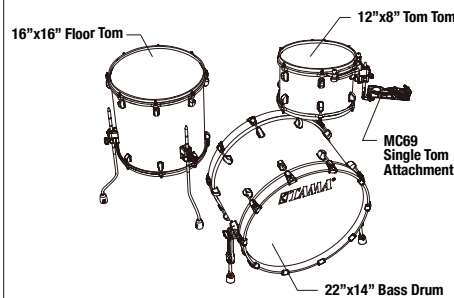

### [22"BD 4pc Shell Kit]

WBR42S w/ Chrome Hardware

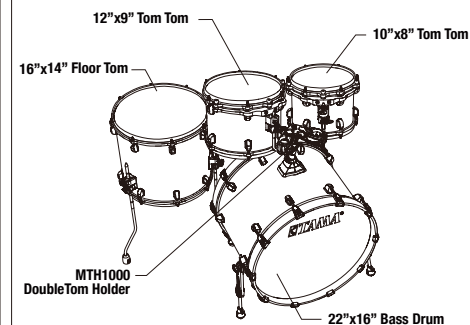

### [22"BD 5pc Shell Kit]

WBR52RZS w/ Chrome Hardware

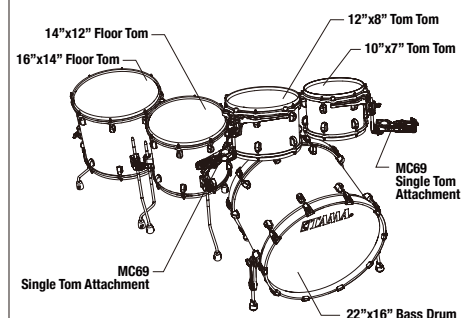

SPECKI T.D. | IN EXTREMO & FAELDER

# INDIVIDUAL MODEL NUMBERS

Diameter	Depth	Model No.
<b>Bass Drums</b> *To order Bass Drum w/ Tom Holder Base, Please substitute "Z" with "M". Ex WBRB22DZ → WBRB22DM		
16"	12"	WBRB16HZ
18"	14"	WBRB18RZ
20"	14"	WBRB20RZ
20"	16"	WBRB20DZ
20"	18"	WBRB20EZ
22"	14"	WBRB22RZ
22"	16"	WBRB22DZ
22"	18"	WBRB22EZ
22"	20"	WBRB22XZ
24"	16"	WBRB24DZ
24"	18"	WBRB24EZ
<b>Floor Toms</b>		
13"	12"	WBRF13R
14"	12"	WBRF14A
14"	14"	WBRF14D
16"	14"	WBRF16A
16"	16"	WBRF16D
18"	16"	WBRF18D
<b>Tom Toms</b>		
8"	6"	WBRT8H
8"	7"	WBRT8A
10"	6.5"	WBRT10H
10"	7"	WBRT10R
10"	8"	WBRT10A
12"	7"	WBRT12H
12"	8"	WBRT12R
12"	9"	WBRT12A
13"	7.5"	WBRT13H
13"	9"	WBRT13R
13"	10"	WBRT13A
14"	11"	WBRT14A
14"	12"	WBRT14D
16"	13"	WBRT16A
16"	14"	WBRT16D
<b>Snare Drums</b>		
13"	6"	WBRS136
14"	5.5"	WBRS55
14"	6.5"	WBRS65
14"	8"	WBRS148

## MODEL NUMBER SYSTEM - Individual Drums

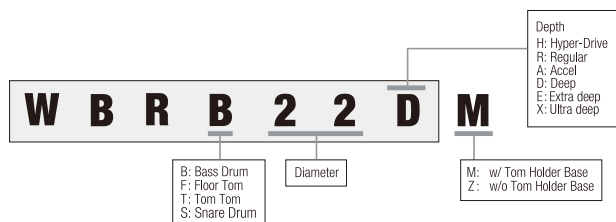

## SPECIFICATIONS

### Shells

TT/FT/SD: 6mm 4ply European Birch + 2 inner ply American Black Walnut  
 BD: 8mm 5ply European Birch + 2 inner ply American Black Walnut

Star-Cast Mounting System    Claw Hooks w/ Rubber Spacers  
 Quick-Lock Tom Bracket        Cushioned Floor Tom Legs  
 EVANS® Heads                    Die-Cast Hoops

## FINISHES (Duracover Wrap)



Surf Green Silk  
SGS



Vintage Marine Pearl  
VMP



Charcoal Onyx  
CCO



Jade Silk  
JDL



Red Oyster  
ROY

# STARCLASSIC PERFORMER

**NEW**

## Lacquer Finish

Tama's newest Starclassic Performer series centers on the newest Tama hybrid shell – maple/birch – to offer drummers a complex, powerful and expressive sound supported by rugged Starclassic performance. Tama's Starclassic Performer series evolves the Starclassic legacy to provide a unique Tama sonic component that redefines the art of professional drum set sound and expression at an undeniable value.

**COLOR** Caramel Aurora

**CAR**

### MBS52RZS basic kit

including:  
 22"x16" bass drum  
 10"x7" tom tom  
 12"x8" tom tom  
 14"x12" floor tom  
 16"x14" floor tom  
 MC69 single tom attachment (x2)  
 [add-on]  
 14"x6.5" snare drum



## KIT CONFIGURATIONS LIST

### [22" BD 5pc Shell Kit]

MBS52RZS w/ Chrome Hardware

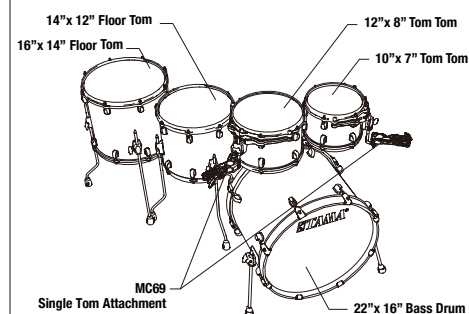

### [22" BD 4pc Shell Kit]

MBS42S w/ Chrome Hardware

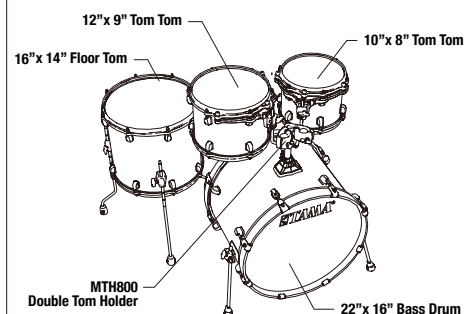

Dániel Gerendás

# INDIVIDUAL MODEL NUMBERS

Diameter	Depth	Model No.
<b>Bass Drums</b> *To order Bass Drum w/ Tom Holder Base, Please substitute "Z" with "M". Ex MBSB22DZ → MBSB22DM		
18"	14"	MBSB18RZ
20"	14"	MBSB20RZ
22"	16"	MBSB22DZ
22"	18"	MBSB22EZ
24"	16"	MBSB24DZ
<b>Floor Toms</b>		
14"	12"	MBSF14A
14"	14"	MBSF14D
16"	14"	MBSF16A
18"	16"	MBSF18D
<b>Tom Toms</b>		
8"	6"	MBST8H
8"	7"	MBST8A
10"	7"	MBST10R
10"	8"	MBST10A
12"	8"	MBST12R
12"	9"	MBST12A
13"	9"	MBST13R
13"	10"	MBST13A
14"	10"	MBST14R
14"	11"	MBST14A
<b>Snare Drums</b>		
14"	5.5"	MBSS55
14"	6.5"	MBSS65

## MODEL NUMBER SYSTEM - Individual Drums

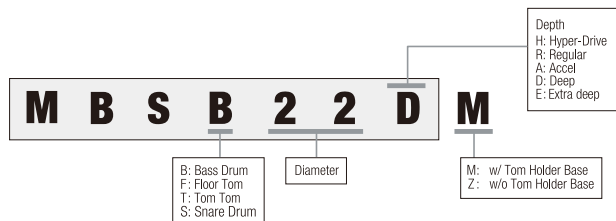

## SPECIFICATIONS

### Shells

TT/FT/SD: 6mm, 4ply Birch + 2 inner ply Maple  
BD: 7mm, 5ply Birch + 2 inner ply Maple

Star-Cast Mounting System    Claw Hooks w/ Rubber Sappers  
Cushioned Floor Tom Legs    EVANS® Heads  
Die-Cast Hoops



JONNY KÖNIG | SCHLAGZEUGMAFIA

## FINISHES (Lacquer)

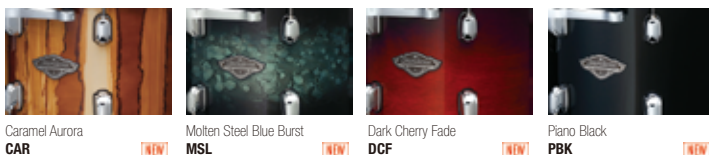

# S.L.P. DRUM KITS -STUDIO MAPLE-

## Lacquer Finish

The Studio Maple kit is very original model in both sound and appearance, with Sound Focus Rings on the inside of the shells and 100% Maple Wood Hoops. It has a focused, warm, woody tone with clear attack, and a relatively short sustain with beautiful decay. While great for live performance, this model really excels in the studio, especially when seeking a warm sound with controlled resonance.



## SPECIFICATIONS

### Shells

All Maple Shell w/Sound Focus Ring  
TT/FT: 5mm 6ply , BD: 7mm 8ply

Maple Wood Hoop  
Direct Flexi-Mount  
EVANS® G1 Coated Head

**COLOR** Gloss Sienna **GSE**

### LMP42RTLS basic kit

including:  
22"x16" bass drum  
10"x7" tom tom  
12"x8" tom tom  
16"x16" floor tom  
MTH1000 double tom holder

[add-on]  
LMP1465F-SEN 14"x6.5" snare drum

## KIT CONFIGURATIONS LIST

[22"BD 4pc Shell Kit]

LMP42RTLS

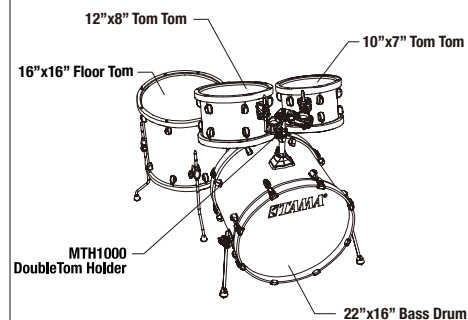

## FINISH (Lacquer)



Gloss Sienna  
**GSE**



ROBERT GRUSS | FEUERSCHWANZ

## INDIVIDUAL MODEL NUMBERS

Diameter	Depth	Model No
<b>Bass Drum</b>		
22"	16"	LMPB22D
<b>Floor Toms</b>		
14"	14"	LMPF14D
16"	16"	LMPF16D
<b>Tom Toms</b>		
10"	7"	LMPT10R
12"	8"	LMPT12R
<b>Snare Drum</b>		
14"	6.5"	LMP1465F

# S.L.P. DRUM KITS -FAT SPRUCE-

## Lacquer Finishes

The Fat Spruce kit features luxurious 100% Spruce shells, which is rarely used as a material on complete drum sets. Its unique sound is fat and open with solid mids and a natural, acoustic vibe not found in more common materials. Furthermore, by utilizing die-cast hoops, it provides a very clear, focused sound.

This kit is also very versatile with a wide tuning range – can go low to medium, optimal for R&B, Blues, and Ballads, or tuned higher to work really well for Jazz and Indie Rock.

And also, its wide tuning range is very attractive. The sound character changes greatly according to tuning. When you need jazz style approach, it is best to tune to high pitch. Also, it can go low to medium, optimal for R&B, Blues, and Ballads, or tuned mid to work really well for Indie Rock.



**COLOR** Turquoise TUQ

### LSP32CS basic kit

including:  
 22"x14" bass drum  
 12"x8" tom tom  
 16"x14" floor tom  
 MTH900BM single tom holder  
 [add-on]  
 LSP146-TUQ 14"x6" snare drum



## KIT CONFIGURATIONS LIST

### [20"BD 3pc Shell Kit]

LSP30CS

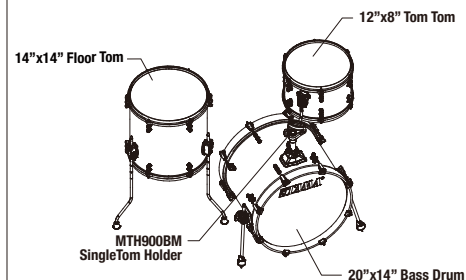

### [22"BD 3pc Shell Kit]

LSP32CS

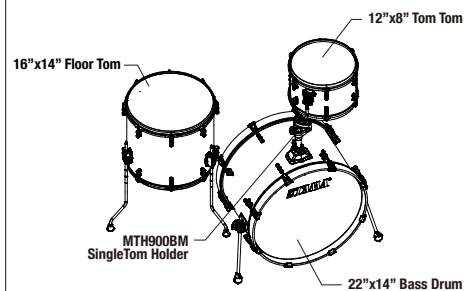

## FINISHES (Lacquer)



Turquoise  
TUQ

Satin Wild Spruce  
TWS

## SPECIFICATIONS

### Shells

All Spruce Shell  
 TT/FT: 6mm 6ply, BD: 8mm 8ply

Die-Cast Hoop  
 Direct Flexi-Mount  
 EVANS® G1 Coated Head

## INDIVIDUAL MODEL NUMBERS

Diameter	Depth	Model No.
<b>Bass Drums</b>		
18"	14"	LSPB18R
20"	14"	LSPB20R
22"	14"	LSPB22R
<b>Floor Toms</b>		
14"	14"	LSPF14D
16"	14"	LSPF16A
<b>Tom Toms</b>		
8"	6"	LSPT8H
10"	7"	LSPT10R
12"	8"	LSPT12R
<b>Snare Drum</b>		
14"	6"	LSP146

# S.L.P. DRUM KITS -DYNAMIC KAPUR-

## Lacquer Finishes

This model features Kapur material, which has caught many drummers' attention for its solid, focused sound and rich mid- to low-end. We paired it with our Sound Arc Hoops for plenty of attack and moderately controlled overtones of the Kapur shells. It offers warm resonance and a very natural, comfortable feel. Because of its slightly dry sound and enhanced attack, it works very well for funk, fusion and gospel. The high volume potential also lends itself perfectly to rock music.



**COLOR** Flat Black **FBK**

### LKP52HTS basic kit

including:  
 22"x16" bass drum  
 10"x6.5" tom tom  
 12"x7" tom tom  
 14"x12" floor tom  
 16"x14" floor tom  
 MTH905N double tom holder

[add-on]  
 LKP1465-FBK 14"x6.5" snare drum

## KIT CONFIGURATIONS LIST

### [22"BD 4pc Shell Kit]

LKP42HTS

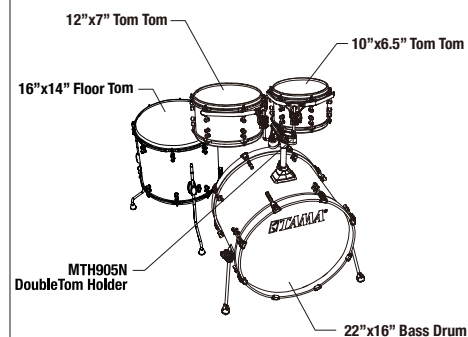

### [22"BD 5pc Shell Kit]

LKP52HTS

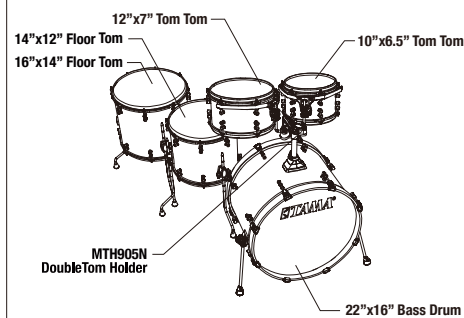

## FINISHES (Lacquer)



Flat Black  
**FBK**

Gloss Black Kapur Burst  
**GKP**

## SPECIFICATIONS

### Shells

All Kapur Shell  
 TT/FT: 6mm 6ply, BD: 7mm 7ply

Sound Arc Hoop  
 Star-Mount System  
 Hyper-Drive Toms

## INDIVIDUAL MODEL NUMBERS

Diameter	Depth	Model No.
<b>Bass Drums</b>		
20"	16"	LKPB20D
22"	16"	LKPB22D
<b>Floor Toms</b>		
14"	12"	LKPF14A
16"	14"	LKPF16A
<b>Tom Toms</b>		
8"	6"	LKPT8H
10"	6.5"	LKPT10H
12"	7"	LKPT12H
<b>Snare Drum</b>		
14"	6.5"	LKP1465



# S.L.P. DRUM KITS -NEW VINTAGE HICKORY-

## Lacquer Finish

The S.L.P. New Vintage Hickory kit features a 100% American Hickory shell. Its just as bright and warm as Maple but even clearer in tone. The 2.3mm Steel Mighty Hoops and Evans G1 Coated head are placed on the shells for an open sound. The lacquered brown Bass Drum hoops with Vintage Marine Pearl wrap inlay add a unique vintage feel to this kit.



**COLOR** Satin Vintage Hickory **SVH**

### LHK38CS basic kit

including:  
 18"x14" bass drum  
 12"x8" tom tom  
 14"x14" floor tom  
 MTH900BM single tom holder

[add-on]  
 LHK145-SVH 14"x5" snare drum

## SPECIFICATIONS

### Shells

All Hickory Shell  
 TT/FT: 5mm 6ply, BD: 7mm 8ply

2.3mm Steel Mighty Hoop  
 Direct Flexi-Mount  
 EVANS® G1 Coated Head

## KIT CONFIGURATIONS LIST

### [18"BD 3pc Shell Kit]

LHK38CS

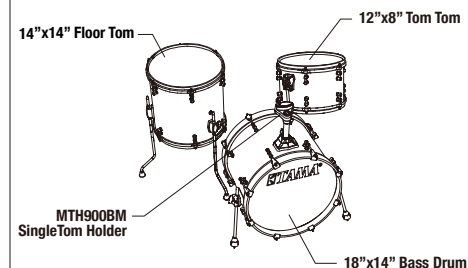

## FINISH (Lacquer)



Satin Vintage Hickory  
**SVH**

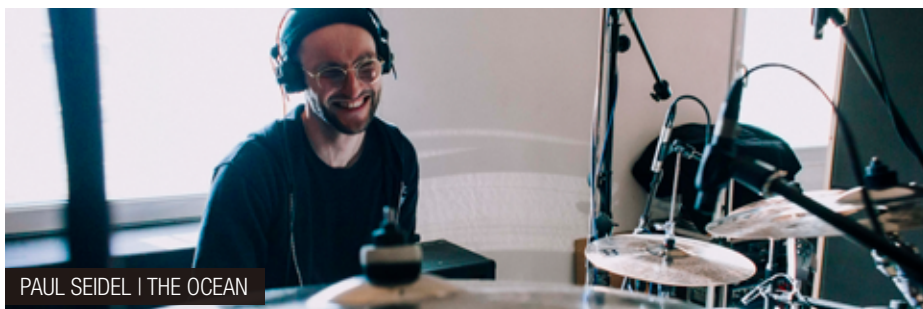

## INDIVIDUAL MODEL NUMBERS

Diameter	Depth	Model No.
<b>Bass Drum</b>		
18"	14"	LHKB18R
<b>Floor Toms</b>		
14"	14"	LHKF14D
16"	14"	LHKF16A
<b>Tom Toms</b>		
8"	6"	LHKT8H
10"	7"	LHKT10R
12"	8"	LHKT12R
<b>Snare Drum</b>		
14"	5"	LHK145

# SUPERSTAR HYPER-DRIVE DUO

## Lacquer Finishes

Superstar Hyper-Drive Duo is a unique and exciting series which will bring new value to the current drumming world. Similar to the groundbreaking work we did with the Superstar Hyper-Drive's extra shallow toms in 2008 - drawing inspiration from recent performances of cutting-edge drummers - we have once again created distinct drum setups which are poised to inspire drummers. Opening the door to new approaches to drumming beyond the standard. The key component of this series is the 10" x 14" snare drum, which we call the "Duo Snare". This drum is unique not only because of its uncommon 10" depth, but also because it is equipped with floor tom legs and brackets. You can tune this drum low and place it where the first floor tom would traditionally go. As such, the snare can function as a low/deep snare with the snare wires engaged, or as a 14" floor tom with the snares off. This can lead to many unique phrasing opportunities.

Once you experience playing on this new kit your eyes and ears will be opened to the infinite range of possibilities, plus it's a lot of fun. Just try it.



**COLOR** Satin Burgundy Vertical Stripe **SGV**

### ML52HZBN2 5pc basic kit

including:  
 22"x16" bass drum  
 10"x6.5" tom tom  
 12"x7" tom tom  
 16"x14" floor tom  
 14"x10" duo snare  
 MC69 single tom attachments (x2)

[add-on]  
 14"x5.5" snare drum

## KIT CONFIGURATIONS LIST

### [20"BD 4pc Shell Kit]

ML40HZBN2

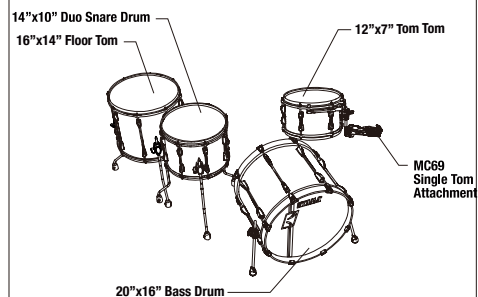

### [22"BD 5pc Shell Kit]

ML52HZBN2

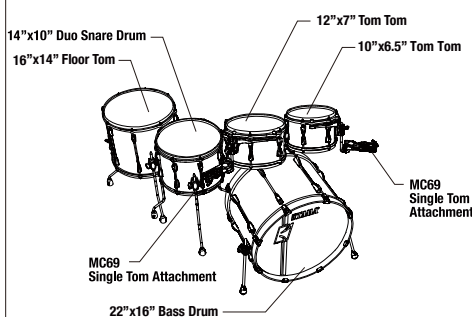

# INDIVIDUAL MODEL NUMBERS

Diameter	Depth	Model No.
<b>Bass Drums</b>		
20"	16"	MLB20DZBN
22"	16"	MLB22DZBN
<b>Floor Toms</b>		
14"	12"	MLF14ALBN
16"	14"	MLF16ALBN
18"	16"	MLF18DLBN
<b>Tom Toms</b>		
8"	6"	MLT8HBN
10"	6.5"	MLT10HBN
12"	7"	MLT12HBN
13"	7.5"	MLT13HBN
14"	8"	MLT14HBN
<b>Snare Drums</b>		
13"	6"	MLS136BN
14"	5.5"	MLS55BN
14"	6.5"	MLS65BN
<b>Duo Snare Drum</b>		
14"	10"	MLS1410LBN

## SPECIFICATIONS

### Shells

All Maple  
TT/FT/SD: 5mm 6ply, BD: 7mm 8ply

Star-Cast Mounting System

Duo Snare

Die-Cast Hoop

EVANS® Power Center

Reverse Dot for Duo Snare

Power Craft II Drum Heads



## FINISHES (Lacquer)

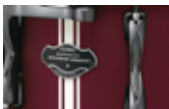

Satin Burgundy Vertical Stripe  
**SGV**



Satin Blue Vertical Stripe  
**SBV**



Satin Silver Vertical Stripe  
**SSV**



Flat Black Vertical Stripe  
**FBV**

# SUPERSTAR HYPER-DRIVE MAPLE

## Lacquer Finishes

Power. Flexibility. Visibility. With TAMA Hyper-Drive kits, your audience will hear your every note and see your every move. Hyper-Drive's unique combination of modern and traditional drum sizes offers sonic power with clarity, unparalleled set-up flexibility, and complete performance visibility.



**COLOR** Seafoam Green **SFG**

### ML52HLZBNS 5pc basic kit

including:  
 22"x18" bass drum  
 10"x6.5" tom tom  
 12"x7" tom tom  
 14"x12" floor tom  
 16"x14" floor tom  
 MC69 single tom attachments (x2)

[add-on]  
 14"x5.5" snare drum

## KIT CONFIGURATIONS LIST

### [22"BD 4pc Shell Kit]

ML42HLZBNS  
 ML42HLZBN w/ HBSW hardware pack

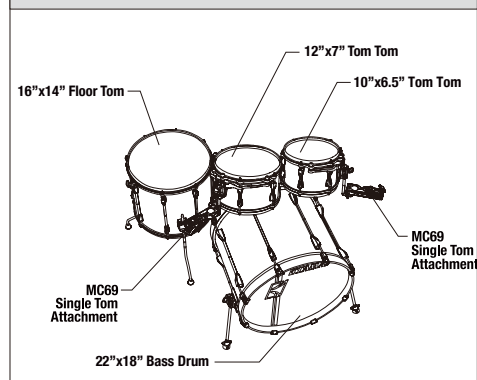

### [22"BD 5pc Shell Kit]

ML52HLZBNS  
 ML52HLZBN w/ HBSW hardware pack

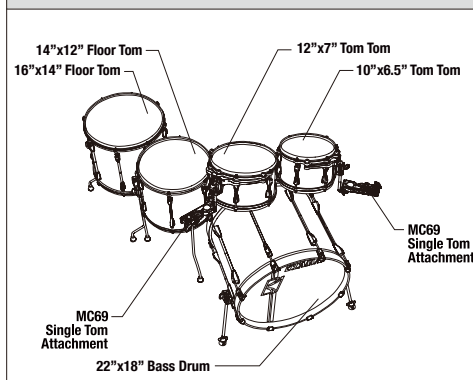

# INDIVIDUAL MODEL NUMBERS

Diameter	Depth	Model No.
<b>Bass Drums</b>		
22"	18"	MLB22DZBN
22"	20"	MLB22XZBN
24"	18"	MLB24EZBN
<b>Floor Toms</b>		
14"	12"	MLF14ABN
16"	14"	MLF16ABN
18"	16"	MLF18DBN
<b>Tom Toms</b>		
8"	6"	MLT8HBN
10"	6.5"	MLT10HBN
12"	7"	MLT12HBN
13"	7.5"	MLT13HBN
14"	8"	MLT14HBN
<b>Snare Drums</b>		
13"	6"	MLS136BN
14"	5.5"	MLS55BN
14"	6.5"	MLS65BN

## SPECIFICATIONS

### Shells

All Maple  
 TT/FT/SD: 5mm 6ply, BD: 7mm 8ply

Star-Cast Mounting System

Hyper-Drive Toms

Die-Cast Hoop

Power Craft II Drum Heads



FABIAN FÜSS | EMIL BULLS

## FINISHES (Lacquer)



Seafoam Green  
SFG



Dark Mocha Fade  
DMF



Flat Black  
FBK



Satin Arctic Pearl  
SAP



Classic Cherry Wine  
CCW

# SUPERSTAR HYPER-DRIVE MAPLE

Unicolor Wrap Finishes



**COLOR** Midnight Gold Sparkle **MGD**

## MK52HLZBNS 5pc basic kit

including:  
 22"x18" bass drum  
 10"x6.5" tom tom  
 12"x7" tom tom  
 14"x12" floor tom  
 16"x14" floor tom  
 MC69 single tom attachments (x2)

[add-on]  
 14"x5.5" snare drum

## KIT CONFIGURATIONS LIST

### [22"BD 4pc Shell Kit]

MK42HLZBNS  
 MK42HLZBN w/ HBSW hardware pack

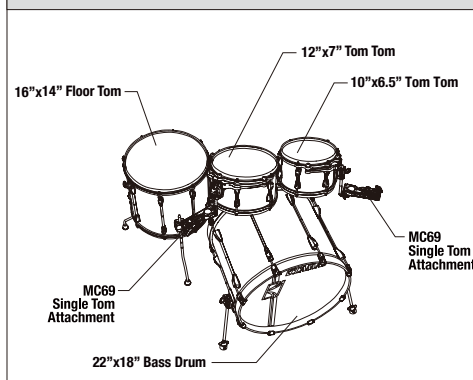

### [22"BD 5pc Shell Kit]

MK52HLZBNS  
 MK52HLZBN w/ HBSW hardware pack

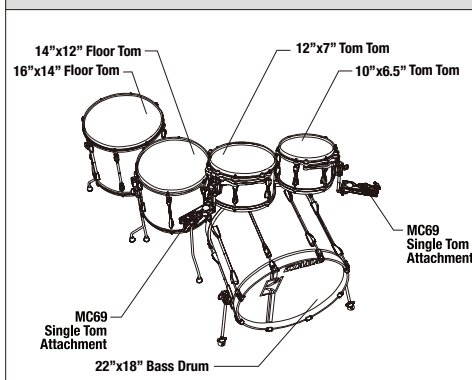

ROMAN BAUMGARTNER

# INDIVIDUAL MODEL NUMBERS

Diameter	Depth	Model No.
<b>Bass Drums</b>		
22"	18"	MKB22EZBN
22"	20"	MKB22XZBN
24"	18"	MKB24EZBN
<b>Floor Toms</b>		
14"	12"	MKF14ABN
16"	14"	MKF16ABN
18"	16"	MKF18DBN
<b>Tom Toms</b>		
8"	6"	MKT8HBN
10"	6.5"	MKT10HBN
12"	7"	MKT12HBN
13"	7.5"	MKT13HBN
14"	8"	MKT14HBN
<b>Snare Drums</b>		
13"	6"	MKS136BN
14"	5.5"	MKS55BN
14"	6.5"	MKS65BN

## SPECIFICATIONS

### Shells

All Maple  
TT/FT/SD: 5mm 6ply, BD: 7mm 8ply

Star-Cast Mounting System

Hyper-Drive Toms

Die-Cast Hoop

Power Craft II Drum Heads

## FINISHES (Unicolor Wrap)



Bright Orange Sparkle  
**BOS**



Midnight Gold Sparkle  
**MGD**



Indigo Sparkle  
**ISP**



Brushed Charcoal Black  
**BCB**



Sugar White  
**SGW**



JAMES STEWART | VADER

# SUPERSTAR CLASSIC MAPLE

**NEW**

## Exotic Finishes

For more than forty years, the Superstar name has stood for groundbreaking design, superior build quality, sterling tone, and clear projection. Superstar Classic once again upholds tradition by raising the bar for discerning drummers—and remarkably—does it while also lowering the price. Drawing on Superstar of the past, its classic TAMA T-shape badge and streamlined low-mass single lugs point to the simpler state of art of the 70's, while the ingenious Star-Mount system and the thinner gauge 100% maple shells eclipse anything in its class.

**COLOR** Gloss Lacebark Pine Fade **PGLP**

### CL72RS 7pc basic kit

including:  
 22"x16" bass drum  
 8"x6" tom tom  
 10"x7" tom tom  
 12"x8" tom tom  
 14"x12" floor tom  
 16"x14" floor tom  
 14"x6.5" snare drum  
 MTH600 double tom holder  
 MC69 single tom attachment



## KIT CONFIGURATIONS LIST

### [22"BD 5pc Shell Kit]

CL52KRS  
 CL52KR w/SMSW hardware pack

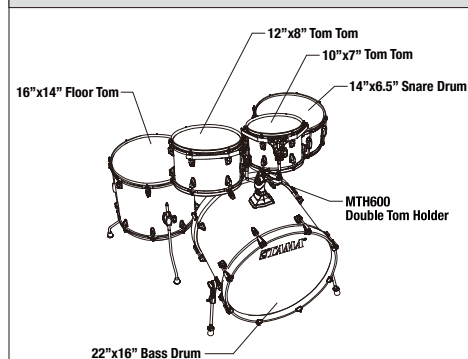

### [22"BD 7pc Shell Kit]

CL72RS  
 CL72R w/SMSW hardware pack

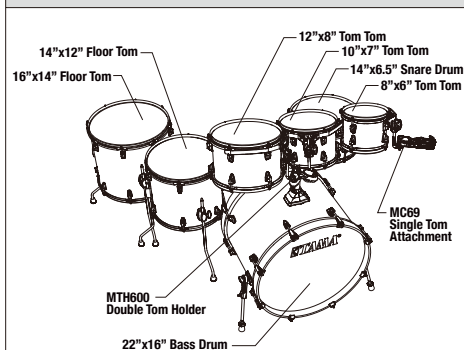



# INDIVIDUAL MODEL NUMBERS

Diameter	Depth	Model No.
<b>Bass Drums</b>		
18"(w/ bass drum lifter)	14"	CLB18RL
20"	16"	CLB20D
22"	16"	CLB22D
24"	16"	CLB24D
<b>Floor Toms</b>		
14"	12"	CLF14A
14"	14"	CLF14D
16"	14"	CLF16A
18"	16"	CLF18D
<b>Tom Toms</b>		
8"	6"	CLT8H
10"	7"	CLT10R
12"	8"	CLT12R
13"	9"	CLT13R
<b>Snare Drums</b>		
14"	5"	CLS145
14"	6.5"	CLS1465

## SPECIFICATIONS

### Shells

TT/FT/SD: 5mm 4ply Maple + 2 outer ply  
Lacebark Pine  
BD: 7mm 6ply Maple + 2 outer ply Lacebark Pine

### Star-Mount System

Low-Mass Lugs

Power Craft II Drum Heads



KERIM LECHNER | SEPTICFLESH

## FINISHES (Lacquer)



Gloss Lacebark Pine Fade  
PGLP



Gloss Java Lacebark Pine  
PGJP



Gloss Sapphire Lacebark Pine  
PGHP



Gloss Garnet Lacebark Pine  
PGGP

# SUPERSTAR CLASSIC MAPLE

Lacquer Finishes

**COLOR** Light Emerald Blue Green **LEG**

## CL52KRS 5pc basic kit

including:  
 22"x16" bass drum  
 10"x7" tom tom  
 12"x8" tom tom  
 16"x14" floor tom  
 14"x6.5" snare drum  
 MTH600 double tom holder



## KIT CONFIGURATIONS LIST

### [18" BD 4pc Shell Kit]

**CL48S**  
**CL48** w/ SWS hardware pack

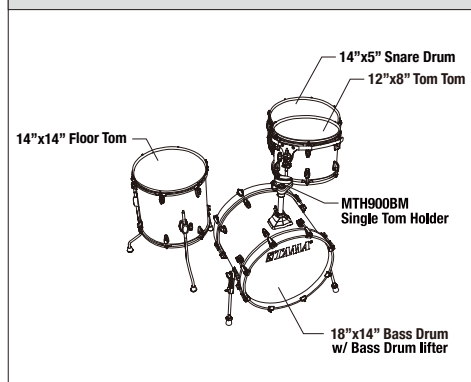

### [20"BD 5pc Shell Kit]

**CL50RS**  
**CL50R** w/ SWS hardware pack

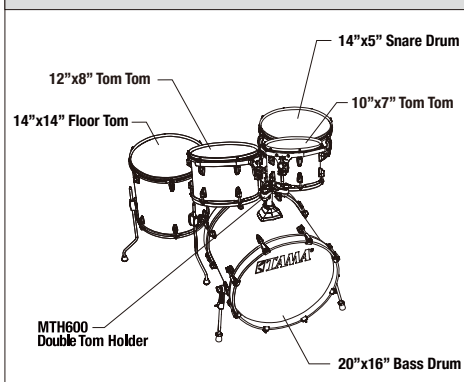

### [22"BD 5pc Shell Kit]

**CL52KRS**  
**CL52KR** w/SWS hardware pack

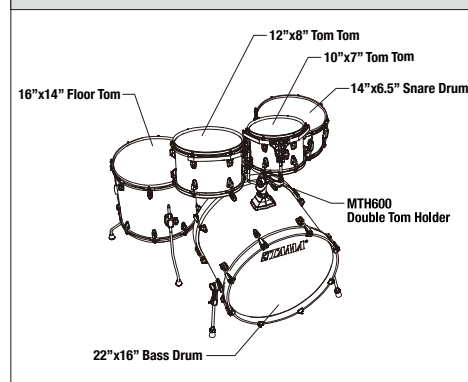

# INDIVIDUAL MODEL NUMBERS

Diameter	Depth	Model No.
<b>Bass Drums</b>		
18"(w/ bass drum lifter)	14"	CLB18RL
20"	16"	CLB20D
22"	16"	CLB22D
24"	16"	CLB24D
<b>Floor Toms</b>		
14"	12"	CLF14A
14"	14"	CLF14D
16"	14"	CLF16A
18"	16"	CLF18D
<b>Tom Toms</b>		
8"	6"	CLT8H
10"	7"	CLT10R
12"	8"	CLT12R
13"	9"	CLT13R
<b>Snare Drums</b>		
14"	5"	CLS145
14"	6.5"	CLS1465

## SPECIFICATIONS

### Shells

All Maple Shell  
 TT/FT/SD: 5mm 6ply  
 BD: 7mm 8ply

Star-Mount System

Low-Mass Lugs

Power Craft II Drum Heads



## FINISHES (Lacquer)



Blue Lacquer Burst  
**BAB**



Coffee Fade  
**CFF**



Tangerine Lacquer Burst  
**TLB**

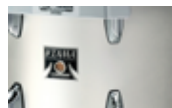

Satin Arctic Pearl  
**SAP**

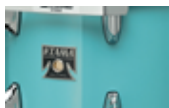

Light Emerald Blue Green  
**LEG**



Transparent Black Burst  
**TPB**

# SUPERSTAR CLASSIC MAPLE

Unicolor Wrap Finishes

COLOR Vintage White Sparkle

VWS

## CK52KRS 5pc basic kit

including:  
 22"x16" bass drum  
 10"x7" tom tom  
 12"x8" tom tom  
 16"x14" floor tom  
 14"x6.5" snare drum  
 MTH600 double tom holder



## KIT CONFIGURATIONS LIST

### [18" BD 4pc Shell Kit]

CK48S  
 CK48 w/ SMSW hardware pack

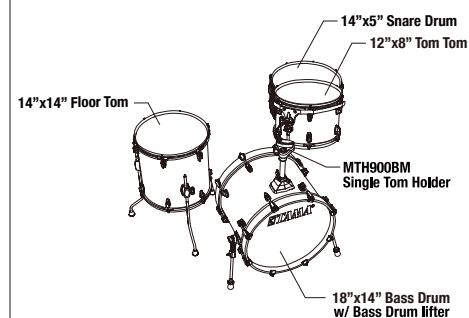

### [20"BD 5pc Shell Kit]

CK50RS  
 CK50R w/ SMSW hardware pack

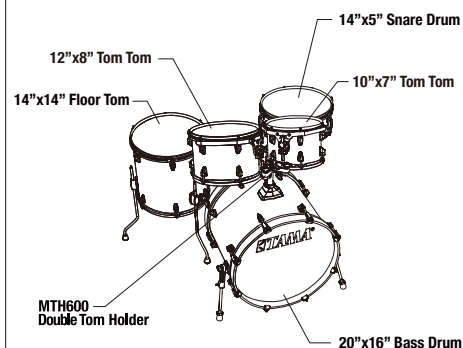

### [22"BD 5pc Shell Kit]

CK52KRS  
 CK52KR w/ SMSW hardware pack

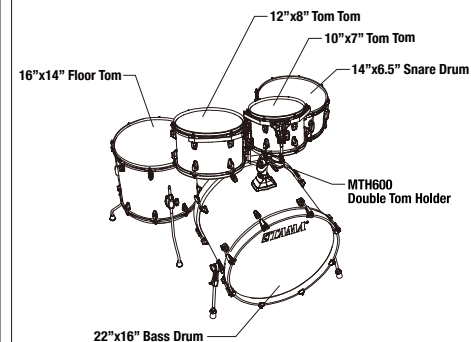

# INDIVIDUAL MODEL NUMBERS

Diameter	Depth	Model No.
<b>Bass Drums</b>		
18"(w/ bass drum lifter)	14"	CKB18RL
20"	16"	CKB20D
22"	16"	CKB22D
24"	16"	CKB24D
<b>Floor Toms</b>		
14"	12"	CKF14A
14"	14"	CKF14D
16"	14"	CKF16A
18"	16"	CKF18D
<b>Tom Toms</b>		
8"	6"	CKT8H
10"	7"	CKT10R
12"	8"	CKT12R
13"	9"	CKT13R
<b>Snare Drums</b>		
14"	5"	CKS145
14"	6.5"	CKS1465

## SPECIFICATIONS

### Shells

All Maple Shell  
 TT/FT/SD: 5mm 6ply  
 BD: 7mm 8ply

Star-Mount System

Low-Mass Lugs

Power Craft II Drum Heads



## FINISHES (Unicolor Wrap)



Indigo Sparkle  
ISP



Midnight Gold Sparkle  
MGD



Dark Red Sparkle  
DRP



Vintage White Sparkle  
VWS

# IMPERIALSTAR

## Unicolor Wrap Finishes

With over 40 years of drum building experience, TAMA knows what drummers really want. With this in mind we sought out to design an affordable yet durable kit that retained many high-end features you'll find in our Superstar, and Starclassic lines. What we came up with was Imperialstar. Every aspect of the modern drum kit was exhaustively examined, reexamined, and then improved before it was accepted as part of the Imperialstar design.

**NEW**



**COLOR** Natural Zebra wood Wrap **NZW**

### IE52KH6W 22" Bass Drum 5pc basic kit

**Drums:** 22"x16" bass drum, 10"x7" & 12"x8" tom toms, 16"x15" floor tom, 14"x5" snare drum.

**Hardware:** double tom holder, hi-hat stand, drum pedal, snare stand, boom cymbal stand, straight cymbal stand, drum throne.

### Including MEINL HCS BRONZE Cymbals

14" Hi-hat, 16" Crash, 20" Ride



**MEINL** HCS Bronze

Imperialstar all-in-one "READY-TO-ROCK" packages not only have everything you need to rock, you'll rock better with HCS genuine bronze cymbals from Meinl®, the cymbal maker of choice for many of today's new generation drummers.

## KIT CONFIGURATIONS LIST

### [18"BD 5pc Kit w/ Hardware]

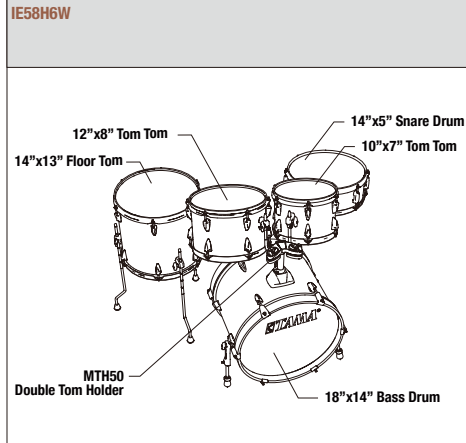

### [20"BD 5pc Kit w/ Hardware]

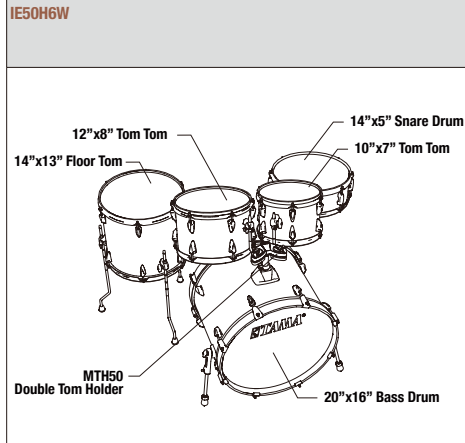

### [22"BD 5pc Kit w/ Hardware]

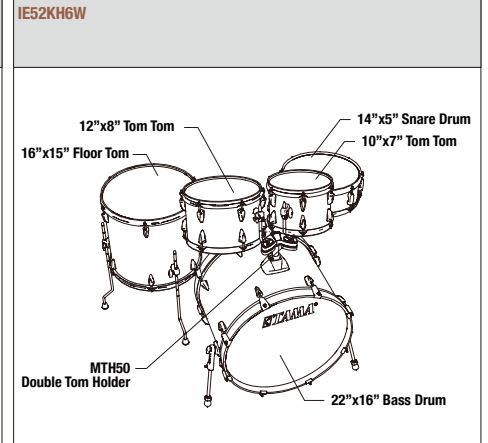

### [22"BD 6pc Kit w/ Hardware]

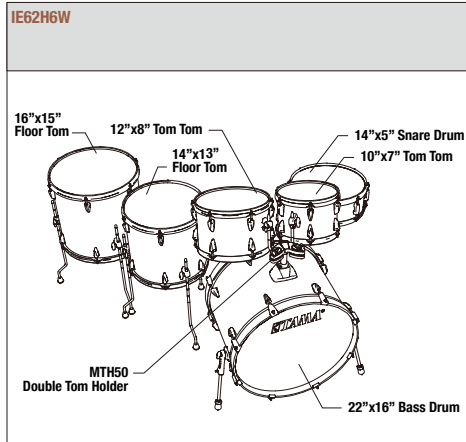

# INDIVIDUAL MODEL NUMBERS

Diameter	Depth	Model No.
<b>Bass Drums</b>		
18"	14"	IEB18RW
20"	16"	IEB20DW
22"	16"	IEB22DW
<b>Floor Toms</b>		
14"	13"	IEF14R
16"	15"	IEF16R
18"	16"	IEF18D
<b>Tom Toms</b>		
8"	6.5"	IET8H
10"	7"	IET10R
12"	8"	IET12R
13"	9"	IET13R
<b>Snare Drums</b>		
14"	5"	IES145
14"	6.5"	IES1465

## SPECIFICATIONS

### Shells

All Poplar Shell: 8mm 6ply

Omnisphere Tom Holder  
 Wood Bass Drum Hoops  
 Double Braced Hardware



SIMON GATTRINGER | JOHANNES OERDING & DRESCHHEADS

## FINISHES (Unicolor Wrap)



Natural Zebra wood Wrap  
**NZW**

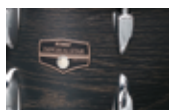

Black Oak Wrap  
**BOW**



Burgundy Walnut Wrap  
**BWW**



Vintage White Sparkle  
**VWS**

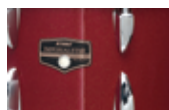

Candy Apple Mist  
**CPM**

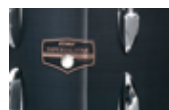

Hairline Black  
**HBK**



Hairline Blue  
**HLB**

# RHYTHM MATE

## Unicolor Wrap Finishes

TAMA's entry-level Rhythm Mate drum kit provides the precise bearing edges for easy tuning that beginners need and the wide tuning range that pros demand. TAMA's original Accu-Tune Bass Drum Hoops offer faster, more consistent tuning than traditional metal hoops. And if that wasn't enough, the hardware is equipped with double-braced legs for increased stability. TAMA Rhythm Mate drums are changing the way entry-level kits are designed.



**COLOR** Red Stream **RDS**

### RM52KH6 5pc basic kit w/ Hardware

**Drums:**  
22"x16" bass drum, 10"x7" & 12"x8" tom toms, 16"x15" floor tom, 14"x5" snare drum.

**Hardware:**  
double tom holder, hi-hat stand, drum pedal, snare stand, boom cymbal stand, straight cymbal stand, drum throne

### Including MEINL BCS Brass Cymbals

14" Hi-hat, 16" Crash, 20" Ride



Rhythm Mate all-in-one "READY-TO-ROCK" packages not only have everything you need to rock, you'll rock better with BCS genuine brass cymbals from Meinl®, the cymbal maker of choice for many of today's new generation drummers.



## KIT CONFIGURATIONS LIST

[20"BD 5pc Kit w/ Hardware]

RM50YH6

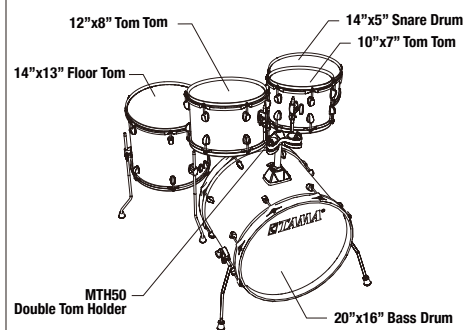

[22"BD 5pc Kit w/ Hardware]

RM52KH6

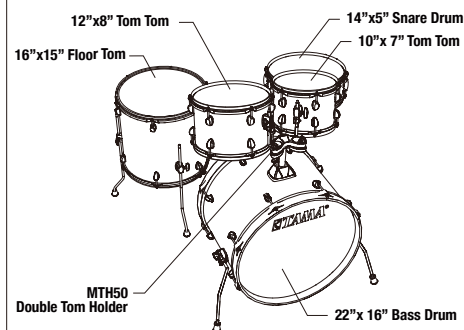

## SPECIFICATIONS

Shells

All Poplar Shell: 8mm 9ply

Omnisphere Tom Holder  
Accu-Tune Bass Drum Hoops  
Double Braced Hardware

## FINISHES (Unicolor Wrap)



Red Stream  
RDS



Galaxy Silver  
GXS



Charcoal Mist  
CCM



Hairline Blue  
HLB



Black  
BK



# CLUB-JAM

## Lacquer Finish

The "Club-JAM" Kit adopts some ideas from vintage kits, such as a cymbal holder mounted directly on the bass drum shell and curved bass drum spurs, further setting it apart from the typical compact kit. Focused yet deep sound from poplar shell is just right for small and intimate gigs. Its compact size and configuration make it ideal for working drummers, and it fits comfortably on just about any stage.



**COLOR** Satin Blonde **SBO**

### LJL48S 4pc basic kit

**Drums:**  
18"x12" bass drum, 10"x7" tom tom, 14"x7" floor tom, 13"x5" snare drum.

**Hardware:**  
single tom holder, cymbal holder.

## SPECIFICATIONS

### Shells

7mm 7ply Poplar + 1 outer ply Phoenix Tree

Bass Drum Mounted Cymbal Holder  
Bass Drum Wood Hoops  
Compact Sizes for Easy Transport  
DSS48LJ Bag Set Sold Separately

## KIT CONFIGURATIONS LIST

[18"BD 4pc Shell Kit]

LJL48S

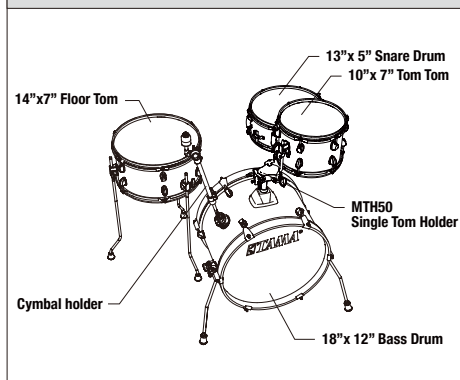

GEORG LENHARDT | DIE APOKALYPTISCHEN REITER

## FINISHES (Lacquer)



Satin Blonde  
SBO

# CLUB-JAM

Unicolor Wrap Finishes



**COLOR** Aqua Blue **AQB**

## LJK48S 4pc basic kit

**Drums:**  
18"x12" bass drum, 10"x7" tom tom, 14"x7" floor tom, 13"x5" snare drum.

**Hardware:**  
Single tom holder, cymbal holder.

## SPECIFICATIONS

### Shells

All Poplar Shell: 8mm 9ply

Bass Drum Mounted Cymbal Holder  
Bass Drum Wood Hoops  
Compact Sizes for Easy Transport  
DSS48LJ Bag Set Sold Separately

## KIT CONFIGURATIONS LIST

[18"BD 4pc Shell Kit]

LJK48S

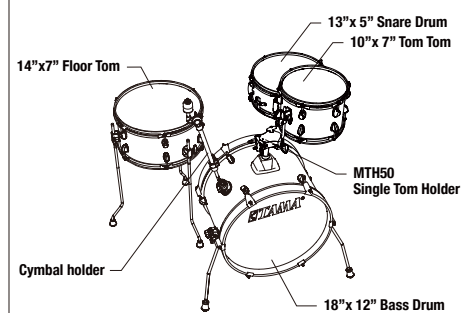

FRANK JOOSS | FIDDLER'S GREEN

## FINISHES (Unicolor Wrap)



Aqua Blue  
AQB

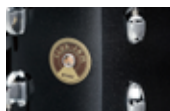

Charcoal Mist  
CCM



Galaxy Silver  
GXS

# CLUB-JAM MINI

## Unicolor Wrap Finishes

The simple and sweet TAMA Club-JAM Mini kit is just a kick and snare. Its clear yet deep sound from the poplar shell is just right for those small and intimate gigs. While its compact size and configuration fit comfortably at any small venue or street show. The drum bag set for this kit (DSS28LJ) allows for smooth transportation (sold separately). If one needs to configure it as a regular drum kit, also available are add-on drums including the 10"x7" tom tom with attachment and a 14"x7" floor tom.



**COLOR** Charcoal Mist **CCM**

### LJK28S 2pc basic kit

**Drums:**  
18"x7" bass drum, 12"x5" snare drum.

### LJKT10F14 Add-on pack

Add-on tom and floor tom package is sold separately.  
10"x7" tom tom, 14"x7" floor tom, single tom attachment

## SPECIFICATIONS

### Shells

All Poplar Shell: 8mm 9ply

### Bass Drum Wood Hoops

LJKT10F14 Add-on Kit sold separately  
(10"x6.5" TT, 14"x07" FT, Single Tom Attachment)

DSS28LJ Bag Set sold separately

## KIT CONFIGURATIONS LIST

### [18"BD 2pc Shell Kit]

LJK28S

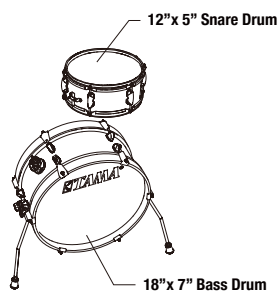

HANNES GROSSMANN | TRIPTYKON

## FINISHES (Unicolor Wrap)

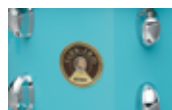

Aqua Blue  
AQB

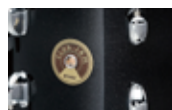

Charcoal Mist  
CCM



Galaxy Silver  
GXS

# CLUB-JAM SUITCASE

## Unicolor Wrap Finishes

The Club-JAM Suitcase kit features the ultimate portability, and is the perfect addition to the Club-JAM family. The bass drum can be divided into two pieces, allowing the tom tom and floor tom to be stored inside for easy transportation by utilizing a specially designed bag (DSS36LJ, sold separately). The 15" deep, 16" diameter bass drum offers a big sound in a compact size. This model offers an authentic drum sound with the convenience of single case portability.

**NEW**



**COLOR** Indigo Sparkle **ISP**

### LJK36S 16" Bass Drum 3pc basic kit

**Drums:**  
16"x15" bass drum w/ bass drum lifter, 10"x7" tom tom, 12"x6" floor tom.

**Hardware:**  
single tom attachment.

## SPECIFICATIONS

### Shells

All Poplar Shell: 8mm 9ply

- Bass Drum Lifter
- Bass Drum Natural Wood Hoops
- Stackable Design
- DSS36LJ Bag Set Sold Separately

## KIT CONFIGURATION LIST

[16"BD 3pc Shell Kit]

LJK36S

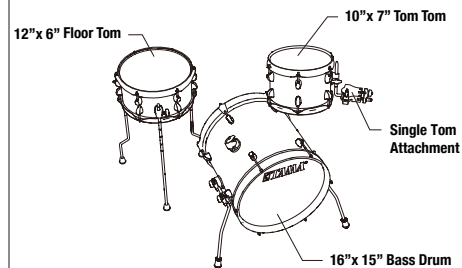

JAN "STIXX" PFENNIG | KONTRA K

## FINISH (Unicolor Wrap)



Indigo Sparkle  
ISP



# CLUB-JAM FLYER

## Unicolor Wrap Finishes

The Club-JAM Flyer is the ultimate compact-sized drum kit. It features a 14"x10" bass drum with bass drum lifter, 8"x6" tom tom, 10"x9" floor tom and a 10"x5" snare drum. The Club-JAM Flyer kit delivers a very-well balanced authentic drum sound despite its smaller-sized shells. The Club-JAM Flyer kit's compact size and configuration make it perfect for any small venue or street show. A special drum bag set for the Club-JAM Flyer kit allows for easy transportation (DSS44LJ / sold separately).

**NEW**



**COLOR** Aqua Blue **AQB**

### LJK44S 4pc basic kit

**Drums:**  
14"x10" bass drum w/ bass drum lifter, 8"x6" tom tom, 10"x9" floor tom, 10"x5" snare drum.

**Hardware:**  
single tom holder.

## SPECIFICATIONS

### Shells

All Poplar Shell: 8mm 9ply

Bass Drum Lifter

Bass Drum Natural Wood Hoops

Compact Sizes for Easy Transport

DSS44LJ Bag Set Sold Separately

## KIT CONFIGURATIONS LIST

[14"BD 4pc Shell Kit]

LJK44S

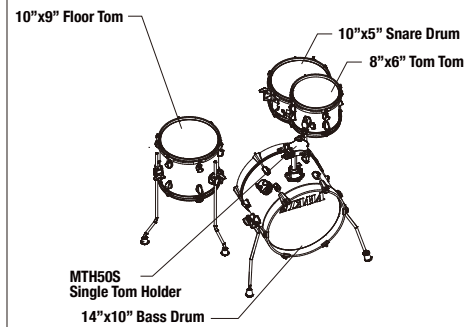

JANN HILLRICHS | NAILED TO OBSCURITY

## FINISHES (Unicolor Wrap)



Aqua Blue  
**AQB**



Candy Apple Mist  
**CPM**

# COCKTAIL-JAM

## Unicolor Wrap Finishes

The Cocktail-JAM Kit™ is a TAMA original in both appearance and sound. It's ideal for hip-hop, jazz, intimate acoustic settings, and tight rehearsal rooms. Completely compact, this kit can easily be set up and played using a throne in spaces much smaller than a typical drum set. Additionally, the Cocktail-JAM Kit and its hardware can be easily packed into just two bags (included with the kit), making it super portable and easy to transport to any gig. Have fun jamming with the Cocktail-JAM Kit!



**COLOR** Indigo Sparkle **ISP**

### CJB46C basic kit w/ cymbal attachments

**Drums:**  
16"x6" bass drum, 10"x5" tom tom, 14"x5.5" floor tom, 12"x5" snare drum, Sound Focus Pad, drum bag, hardware bag.

**Hardware:**  
single tom attachments (x2), single pedal, cymbal attachment, hi-hat attachment

## SPECIFICATIONS

**Shells**  
All Birch Shells  
TT/FT/SD: 6mm 6ply  
BD: 8mm 7ply

Sound Focus Pad  
Specially Designed Bags Included

## KIT CONFIGURATIONS LIST

### [16"BD 4pc Kit with clamp kit]

CJB46C w/ MCAX5366 Clamp kit

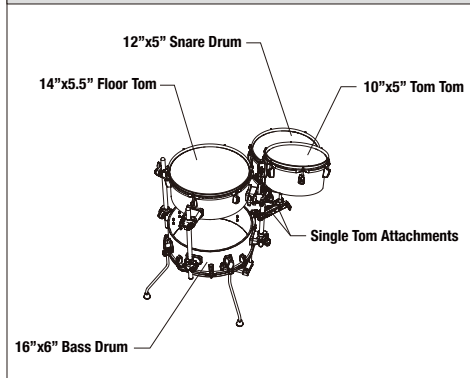

JANOSCH RATHMER | LONG DISTANCE CALLING

## FINISHES (Unicolor Wrap)



Bright Orange Sparkle  
**BOS**



Indigo Sparkle  
**ISP**



Midnight Gold Sparkle  
**MGD**

# COCKTAIL-JAM MINI

## Unicolor Wrap Finishes

The Tama Cocktail-JAM Mini Kit is a Tama original, in both appearance and sound. This kit is similar to Tama's Cocktail-JAM kit, but each drum is 2" smaller in diameter on the Cocktail-JAM Mini kit, making this kit even more compact and convenient. This kit is great for hip-hop, jazz, or any music style requiring a tight sonic conception. Especially at-home in intimate acoustic settings and tight rehearsal rooms, the Cocktail-JAM Mini kit can be set up in the traditional drum set position, yet with a super small footprint.

**NEW**



**COLOR** Hairline Black **HBK**

### CJP44C basic kit w/ cymbal attachments

**Drums:**  
14"x6" bass drum, 8"x5" tom tom, 12"x5.5" floor tom, 10"x5" snare drum, Sound Focus Pad, drum bag, hardware bag.

**Hardware:**  
single tom attachments (x2), single pedal, cymbal attachment, hi-hat attachment.

## SPECIFICATIONS

### Shells

All Poplar Shells : 7.5mm, 6ply

Sound Focus Pad

Specially Designed Bags Included

## KIT CONFIGURATION LIST

[14"BD 4pc Kit with clamp kit]

CJP44C w/ MCAX5366 Clamp kit

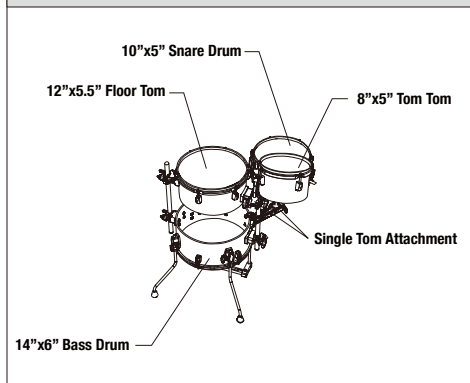

JOHANNES SCHEER | MARATHONMANN

## FINISH (Unicolor Wrap)

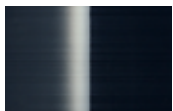

Hairline Black  
**HBK**

**NEW**

# SNARE DRUMS

- Note: For more individual sizes and finishes see STAR drums product page -

TAMA has a wide variety of snare drum options to complement our array of drum kits. From our super high end STAR snare drums to the METALWORKS series, which offers quality at a great price, there is a model to fit every drummer's desired sound and budget.



## STAR BUBINGA



Color: Natural Indian Laurel -LNTI

### TBS1465S

MADE IN JAPAN

Please refer to the STAR Bubinga drum kit page to see available sizes, finishes, and inlay options.

Size: 14"x6.5"  
Lug: MSL90S  
Hoop: Die-Cast Hoop (8 hole)  
Strainer/Butt: MLS50A/MLS50B  
Snare Wire: 14"=MS20RL14C,  
13"=MS20RL13C

## STAR MAPLE



Color: Gloss Natural Curly Maple -RGCM

### TMS1465S

MADE IN JAPAN

Please refer to the STAR Maple drum kit page to see available sizes, finishes, and inlay options.

Size: 14"x6.5"  
Lug: MSL90S  
Hoop: Die-Cast Hoop (8 hole)  
Strainer/Butt: MLS50A/MLS50B  
Snare Wire: 14"=MS20RL14C,  
13"=MS20RL13C

## STAR WALNUT



Color: Garnet Japanese Sen Burst - AGJB

### TWS1465

MADE IN JAPAN

Please refer to the STAR Walnut drum kit page to see available sizes and finishes.

Size: 14"x6.5"  
Lug: MSL90S  
Hoop: Die-Cast Hoop (8 hole)  
Strainer/Butt: MLS50A/MLS50B  
Snare Wire: 14"=MS20RL14C,  
13"=MS20RL13C

## STAR SOLID MAPLE



Color: Oiled Natural Maple -OMP

### TLM146S

MADE IN JAPAN

Shell: 8mm Solid Maple, w/ 8mm Sound Focus Rings  
Size: 14"x6"  
Lug: MSL90S  
Hoop: Die-Cast Hoop (8 hole)  
Strainer/Butt: MLS50A/MLS50B  
Snare Wire: MS20RL14C  
Color: Oiled Natural Maple (OMP)  
[Inlay Option] Outside Inlay, or w/o Inlay

## STAR SOLID MAHOGANY



Color: Oiled Natural Mahogany -OMH

### TLH146S

MADE IN JAPAN

Shell: 7mm Solid Mahogany w/ 7mm Sound Focus Rings  
Size: 14"x6"  
Lug: MSL90S  
Hoop: Die-Cast Hoop (8 hole)  
Strainer/Butt: MLS50A/MLS50B  
Snare Wire: MS20RL14C  
Color: Oiled Natural Mahogany (OMH)  
[Inlay Option] Outside Inlay, or w/o Inlay

## STAR STAVE WALNUT



Color: Oiled Natural Walnut -OWN

### TVW146S

MADE IN JAPAN

Shell: 10mm, 16pcs Stave Walnut  
Size: 14"x6"  
Lug: MSL90S  
Hoop: Die-Cast Hoop (8 hole)  
Strainer/Butt: MLS50A/MLS50B  
Snare Wire: MS20RL14C  
Color: Oiled Natural Walnut (OWN)  
[Inlay Option] Outside Inlay, or w/o Inlay

## STAR STAVE ASH



Color: Oiled Natural Ash -OAS

### TVA146S

MADE IN JAPAN

Shell: 10mm, 16pcs Stave Ash  
Size: 14"x6"  
Lug: MSL90S  
Hoop: Die-Cast Hoop (8 hole)  
Strainer/Butt: MLS50A/MLS50B  
Snare Wire: MS20RL14C  
Color: Oiled Natural Ash (OAS)  
[Inlay Option] Outside Inlay, or w/o Inlay



ANIKA NILLES | NEVELL



## STAR RESERVE BUBINGA/MAPLE



### TMBS158S

MADE IN JAPAN

Shell: 5.5mm, 8ply Bubinga/Maple (1 inner ply Cordia+2ply Bubinga+4ply Maple+1outer ply Olive Ash)  
 Size: 15"x8"  
 Lug: MSL90T  
 Hoop: Brass Mighty Hoop (8 hole)  
 Strainer/Butt: MLS50A / MLS50B  
 Snare Wire: MS20SN15S  
 Color: Caramel Olive Ash Burst (OCOB)

Color: Caramel Olive Ash Burst -OCOB

## STAR RESERVE SOLID MAPLE



### TLM145S

MADE IN JAPAN

Shell: 8mm Solid Maple w/ 8mm Solid Maple Sound Focus Rings  
 Size: 14"x5"  
 Lug: MTL150  
 Hoop: 2.3mm Brass Sound Arc Hoop (8 hole)  
 Strainer/Butt: MLS50A / MLS50B  
 Snare Wire: MS20L14C8  
 Color: Oiled Natural Maple (OMP)

Color: Oiled Natural Maple -OMP



## STAR RESERVE WALNUT/BUBINGA



### TBWS1465S

MADE IN JAPAN

Shell: 5.5mm, 4ply Walnut + 2ply Bubinga + 1 outer ply Claro Walnut w/Maple Sound Focus Rings  
 Size: 14"x6.5"  
 Lug: MTL160  
 Hoop: Sound Arc Hoop (10 Hole)  
 Strainer/Butt: MLS50A / MLS50B  
 Snare Wire: MS20RL14C  
 Color: Gloss Claro Walnut (GCW)

Color: Gloss Claro Walnut -GCW

## STAR RESERVE STAVE JATOBA



### TVJ147S

MADE IN JAPAN

Shell: 10mm, 16pcs Stave Jatoba  
 Size: 14"x7"  
 Lug: MTL160  
 Hoop: Die-Cast Hoop (8 Hole)  
 Strainer/Butt: MLS50A / MLS50B  
 Snare Wire: MS20RL14C  
 Color: Oiled Natural Jatoba (OJT)

Color: Oiled Natural Jatoba -OJT

## STAR RESERVE HAMMERED COPPER



### TCS1465H

MADE IN JAPAN

Shell: 1.5mm Hammered Copper  
 Size: 14"x6.5"  
 Lug: MSL90S  
 Hoop: Customized Brass Mighty Hoop (8 Hole)  
 Strainer/Butt: MLS50A / MLS50B  
 Snare Wire: MS20RL14C

## STAR RESERVE HAMMERED BRASS



### TBRS1455H

MADE IN JAPAN

Shell: 1.5mm Hand Hammered Brass  
 Size: 14"x5.5"  
 Lug: MSL90S  
 Hoop: Customized Brass Mighty Hoop (8 hole)  
 Strainer/Butt: MLS50A / MLS50B  
 Snare Wire: MS20RL14C

## STAR RESERVE HAMMERED ALUMINUM



### TAS1465H

MADE IN JAPAN

Shell: 3mm Hand Hammered Aluminum  
 Size: 14"x6.5"  
 Lug: MSL90SC  
 Hoop: Brass Sound Arc Hoop (8 hole)  
 Strainer/Butt: MLS50A / MLS50B  
 Snare Wire: MS20RL14C

NEW

# STARPHONIC

The New Sound from the Golden Age



## STARPHONIC WALNUT

**NEW**



### PWB147

MADE IN JAPAN

Shell: 6mm, 6ply American Black Walnut Shell + 1 outer ply Black Walnut Burl  
Size: 14"x7"  
Lug: Freedom Lug  
Hoop: Grooved Hoop  
Strainer/Butt: MLS50A/MLS50B  
Snare Wire: MS20RL14C  
Color: Gloss Black Walnut Burl (GWB)

Color: Gloss Black Walnut Burl -GWB

## STARPHONIC MAPLE



### PMM146

MADE IN JAPAN

Shell: 6mm, 6ply Maple + 1 Mappa Burl outer ply  
Size: 14"x6"  
Lug: Freedom Lug  
Hoop: Grooved Hoop  
Strainer/Butt: MLS50A/MLS50B  
Snare Wire: MS20RL14C  
Color: Satin Mappa Burl (STM)

Color: Satin Mappa Burl - STM

## STARPHONIC BUBINGA



### PBC146

MADE IN JAPAN

Shell: 7mm, 8ply Bubinga + 1 Cordia outer ply  
Size: 14"x6"  
Lug: Freedom Lug  
Hoop: Grooved Hoop  
Strainer/Butt: MLS50A/MLS50B  
Snare Wire: MS20RL14C  
Color: Matte Natural Cordia (MNC)

Color: Matte Natural Cordia -MNC

## STARPHONIC BRASS



### PBR146

MADE IN JAPAN

Shell: 1.2mm Brass  
Size: 14"x6"  
Lug: Freedom Lug  
Hoop: Grooved Hoop  
Strainer/Butt: MLS50A/MLS50B  
Snare Wire: MS20RL14C

## STARPHONIC BELL BRASS



### PBB146

MADE IN JAPAN

Shell: 3mm Bell Brass  
Size: 14"x6"  
Lug: Freedom Lug  
Hoop: Grooved Hoop  
Strainer/Butt: MLS50A/MLS50B  
Snare Wire: MS20RL14C

## STARPHONIC COPPER



### PCP147

MADE IN JAPAN

Shell: 1.2mm Copper  
Size: 14"x7"  
Lug: Freedom Lug  
Hoop: Grooved Hoop  
Strainer/Butt: MLS50A/MLS50B  
Snare Wire: MS20RL14C

## STARPHONIC ALUMINUM



### PAL146

MADE IN JAPAN

Shell: 1.2mm Seamless Aluminum  
Size: 14"x6"  
Lug: Freedom Lug  
Hoop: Grooved Hoop  
Strainer/Butt: MLS50A/MLS50B  
Snare Wire: MS20RL14C

## STARPHONIC STAINLESS STEEL



### PSS146

MADE IN JAPAN

Shell: 1mm Stainless Steel w/ R.S.E.  
Size: 14"x6"  
Lug: Freedom Lug  
Hoop: Grooved Hoop  
Strainer/Butt: MLS50A/MLS50B  
Snare Wire: MS20RL14C

## STARPHONIC STEEL



### PST146

MADE IN JAPAN

Shell: 1mm Steel  
 Size: 14"x6"  
 Lug: Freedom Lug  
 Hoop: Grooved Hoop  
 Strainer/Butt: MLS50A/MLS50B  
 Snare Wire: MS20RL14C

## STARPHONIC STEEL



### PST137

MADE IN JAPAN

Shell: 1mm Steel  
 Size: 13"x7"  
 Lug: Freedom Lug  
 Hoop: Grooved Hoop  
 Strainer/Butt: MLS50A/MLS50B  
 Snare Wire: MS20RL13C

## STARCLASSIC MAPLE EXOTIC FINISH



### MES1465U

Please refer to the Starclassic Maple Exotic Finishes drum kit page to see available sizes and finishes.  
 Size: 14"x6.5"  
 Lug: MSL-SCT  
 Hoop: Die-Cast Hoop  
 Strainer/Butt: MLS50A/MLS50B  
 Snare Wire: 14"=MS20RL14C, 13"=MS20RL13C

Color: Tobacco Sunburst Movingui -VTBV



- Note: For more individual sizes and finishes see STARCLASSIC drums product page -

## STARCLASSIC MAPLE LACQUER FINISH



### MAS1455

Please refer to the Starclassic Maple Lacquer Finishes drum kit page to see available sizes and finishes. Antique Maple (ATM) is also available.  
 Size: 14"x5.5"  
 Lug: MSL-SCT  
 Hoop: Die-Cast Hoop  
 Strainer/Butt: MLS50A/MLS50B  
 Snare Wire: 14"=MS20RL14C, 13"=MS20RL13C

Color: Antique Maple -ATM

## STARCLASSIC MAPLE DURACOVER WRAP FINISH



### MRS136

Please refer to the Starclassic Maple Duracover Wrap Finishes drum kit page to see available sizes and finishes.  
 Size: 13"x6"  
 Lug: MSL-SCT  
 Hoop: Die-Cast Hoop  
 Strainer/Butt: MLS50A/MLS50B  
 Snare Wire: 14"=MS20RL14C, 13"=MS20RL13C

Color: Blue and White Oyster -BWO

## STARCLASSIC WALNUT/BIRCH LACQUER FINISH



### WBSS65

Please refer to the Starclassic Walnut/Birch Lacquer Finishes drum kit page to see available sizes and finishes.  
 Size: 14"x6.5"  
 Lug: MSL-SCT  
 Hoop: Die-Cast Hoop  
 Strainer/Butt: MCS70A/MCS70B  
 Snare Wire: 14"=MS20R14S, 13"=MS20R13S

Color: Molten Brown Burst -MBR

## STARCLASSIC WALNUT/BIRCH DURACOVER WRAP FINISH



### WBR65

Please refer to the Starclassic Walnut/Birch Duracover Wrap Finishes drum kit page to see available sizes and finishes.  
 Size: 14"x6.5"  
 Lug: MSL-SCT  
 Hoop: Die-Cast Hoop  
 Strainer/Butt: MCS70A/MCS70B  
 Snare Wire: 14"=MS20R14S, 13"=MS20R13S

Color: Jade Silk -JDL

## STARCLASSIC PERFORMER LACQUER FINISH

NEW



### MBSS65

Please refer to the Starclassic Performer Maple Birch Lacquer Finishes drum kit page to see available sizes and finishes.  
 Size: 14"x6.5"  
 Lug: MSL-SCT  
 Hoop: Die-Cast Hoop  
 Strainer/Butt: MCS70A/MCS70B  
 Snare Wire: 14"=MS20R14S, 13"=MS20R13S

Color: Caramel Auroara - CAR

## STARCLASSIC PERFORMER LACQUER FINISH

NEW



### MBSS55

Please refer to the Starclassic Performer Maple Birch Lacquer Finishes drum kit page to see available sizes and finishes.  
 Size: 14"x5.5"  
 Lug: MSL-SCT  
 Hoop: Die-Cast Hoop  
 Strainer/Butt: MCS70A/MCS70B  
 Snare Wire: 14"=MS20R14S, 13"=MS20R13S

Color: Molten Steel Blue Burst - MSL

## S.L.P. BOLD SPOTTED GUM



### LSG1465

Shell: 6mm, 9ply 100% Spotted Gum  
Size: 14"x6.5"  
Lug: MTL60  
Hoop: 2.3mm Steel Mighty Hoops (10 hole)  
Strainer/Butt: MLS50A / MLS50B  
Snare Wire: MS20RL14C  
Color: Satin Natural Spotted Gum (SNG)

Color: Satin Natural Spotted Gum -SNG

# S.L.P.

---

---

## SOUND LAB PROJECT

## S.L.P. NEW-VINTAGE HICKORY



### LHK145

Shell: 6mm, 6ply 100% Hickory  
Size: 14"x5"  
Lug: MTL30  
Hoop: 2.3mm Steel Mighty Hoops (8 hole)  
Strainer/Butt: MLS50A / MLS50B  
Snare Wire: MS20RL14C  
Color: Satin Vintage Hickory (SVH)

Color: Satin Vintage Hickory -SVH

## S.L.P. G-MAPLE



### LGM146

Shell: 11mm, 12ply Maple + 1 outer ply Mappa Burl  
Size: 14"x6"  
Lug: MSL-SCTBN  
Hoop: Steel Mighty Hoop (10 Hole)  
Strainer/Butt: MLS50ABN / MLS50BBN  
Snare Wire: MS20RL14C  
Color: Kona Mappa Burl (KMB)

Color: Kona Mappa Burl -KMB

## S.L.P. G-MAPLE



### LGM137

Shell: 10mm, 11ply Maple + 1 outer ply Tamo Ash  
Size: 13"x7"  
Lug: MTL60  
Hoop: Die-Cast Hoop (8 hole)  
Strainer/Butt: MLS50A/MLS50B  
Snare Wire: MS20SN13C  
Color: Satin Tamo Ash (STA)

Color: Satin Tamo Ash -STA

## S.L.P. G-WALNUT



### LGW1465

Shell: 9mm, 10ply Walnut  
Size: 14"x6.5"  
Lug: MTL60  
Hoop: Sound Arc Hoop (10 hole)  
Strainer/Butt: MLS50A/MLS50B  
Snare Wire: MS30R14S  
Color: Matte Black Walnut (MBW)

Color: Matte Black Walnut -MBW

## S.L.P. DUO BIRCH



### LBH1410L

Shell: 7mm, 7ply Birch  
Size: 14"x10"  
Lug: MSL-SCT  
Hoop: Sound Arc Hoop (8 hole)  
Strainer/Butt: MCS70A/MCS70B  
Snare Wire: MS20R14S  
Color: Transparent Mocha (TPM)  
\*MTB25E Brackets are equipped.  
\*MFLSL3P Legs are Included.

Color: Transparent Mocha -TPM

## S.L.P. DYNAMIC KAPUR



### LKP1465

Shell: 5mm, 6ply Kapur  
Size: 14"x6.5"  
Lug: MTL60  
Hoop: Sound Arc Hoop (8 hole)  
Strainer/Butt: MLS50A/MLS50B  
Snare Wire: MS20SN14S  
Color: Black Kapur Burst (KPB), Flat Black (FBK)

Color: Black Kapur Burst -KPB

## S.L.P. FAT SPRUCE



### LSP146

Shell: 7mm, 8ply Spruce  
Size: 14"x6"  
Lug: MTL60  
Hoop: Die-Cast Hoop (8 hole)  
Strainer/Butt: MLS50A/MLS50B  
Snare Wire: MS20RL14C  
Color: Wild Satin Spruce (WSS), Turquoise (TUQ)

Color: Wild Satin Spruce -WSS

## S.L.P. CLASSIC MAPLE



### LMP1455

Shell: 7mm, 8ply Maple  
Size: 14"x5.5"  
Lug: MTL50  
Hoop: Sound Arc Hoop (10 hole)  
Strainer/Butt: MLS50A/MLS50B  
Snare Wire: MS20RL14C  
Color: Super Maple (SMP)

Color: Super Maple -SMP

**NEW**

## S.L.P. DYNAMIC BRONZE



### LBR1445

Shell: 1.2mm Antique Aged Bronze  
Size: 14"x4.5"  
Lug: MSL-SCPBN  
Hoop: Die-Cast Hoop (8 hole)  
Strainer/Butt: MCS70ABN/MCS70BBN  
Snare Wire: MS20SN14C

## S.L.P. STUDIO MAPLE



### LMP1465F

Shell: 5mm, 6ply Maple w/ Sound Focus Rings  
Size: 14"x6.5"  
Lug: MSL-SCT  
Hoop: 100% Maple Wood Hoop (8 hole)  
Strainer/Butt: MLS50A/MLS50B  
Snare Wire: MS20SN14S  
Color: Sienna (SEN)

Color: Gloss Sienna -SEN

## S.L.P. BLACK BRASS



### LBR1465

Shell: 1.5mm Brass I Black Nickel  
Size: 14"x6.5"  
Lug: MSL-SCTBN  
Hoop: Steel Mighty Hoop (10 hole)  
Strainer/Butt: MCS70ABN/MCS70BBN  
Snare Wire: MS42R14S

## S.L.P. SONIC STAINLESS STEEL



### LSS1465

Shell: 1.2mm Stainless Steel  
Size: 14"x6.5"  
Lug: MTL60  
Hoop: 3.0mm Ultimate Steel  
Mighty Hoops (10 hole)  
Strainer/Butt: MCS70A/MCS70B  
Snare Wire: MS30R14S



## S.L.P. VINTAGE HAMMERED STEEL



### LST1455H

Shell: 1.2mm Hammered Steel  
Size: 14"x5.5"  
Lug: MTL50  
Hoop: Sound Arc Hoop (10 hole)  
Strainer/Butt: MCS70A/MCS70B  
Snare Wire: MS20RL14C

## S.L.P. CLASSIC DRY ALUMINUM



### LAL1455

Shell: 1.2mm Seamless Aluminum  
Size: 14"x5.5"  
Lug: MCHL5S  
Hoop: Steel Mighty Hoop (8 hole)  
Strainer/Butt: MCS70A/MCS70B  
Snare Wire: MS20RL14C

## S.L.P. BIG BLACK STEEL



### LST148

Shell: 1mm Steel Shell in Matte Black Finish  
Size: 14"x8"  
Lug: MSL35BN  
Hoop: Steel Mighty Hoop (10 hole)  
Strainer/Butt: MCS70ABN/MCS70BBN  
Snare Wire: MS20SN14S



MARIO STÜBLER | RUSSKAJA

## WOODWORKS



Color: Natural Zebrawood Wrap (NZW)

### WP1465BK

Shell: 8mm, 8ply Poplar  
 Size: 14"x6.5"  
 Lug: MSL60SBK  
 Hoop: Triple Flanged Hoop (8 hole)  
 Strainer/Butt: MUS65ABK/MUS60BBK  
 Snare Wire: MS20R14S  
 Color: Natural Zebrawood Wrap (NZW), Black Oak Wrap (BOW)

## WOODWORKS



Color: Black Oak Wrap (BOW)

### WP148BK

Shell: 8mm, 8ply Poplar  
 Size: 14"x8"  
 Lug: MSL60SBK  
 Hoop: Triple Flanged Hoop (8 hole)  
 Strainer/Butt: MUS65ABK/MUS60BBK  
 Snare Wire: MS20R14S  
 Color: Natural Zebrawood Wrap (NZW), Black Oak Wrap (BOW)

## SOUNDWORKS KAPUR



Color: Matte Brown Kapur -MRK

### DKP137

Shell: 6mm, 7ply Kapur  
 Size: 13"x7"  
 Lug: MSL60S  
 Hoop: Sound Arc Hoop (8 hole)  
 Strainer/Butt: MCS70A/MCS70B  
 Snare Wire: MS20R13S  
 Color: Matte Brown Kapur (MRK)

## SOUNDWORKS KAPUR



Color: Matte Brown Kapur -MRK

### DKP146

Shell: 6mm, 7ply Kapur  
 Size: 14"x6"  
 Lug: MSL60S  
 Hoop: Sound Arc Hoop (10 hole)  
 Strainer/Butt: MCS70A/MCS70B  
 Snare Wire: MS20R14S  
 Color: Matte Brown Kapur (MRK)

## SOUNDWORKS MAPLE



Color: Matte Vintage Maple -MVM

### DMP1255

Shell: 5mm, 6ply Maple  
 Size: 12"x5.5"  
 Lug: MSL60S  
 Hoop: Sound Arc Hoop (6 hole, 1.6mm)  
 Strainer/Butt: MCS70A/MCS70B  
 Snare Wire: MS20R12S  
 Color: Matte Vintage Maple (MVM)

## SOUNDWORKS MAPLE



Color: Matte Vintage Maple -MVM

### DMP1465

Shell: 5mm, 6ply Maple  
 Size: 14"x6.5"  
 Lug: MSL60S  
 Hoop: Sound Arc Hoop (10 hole)  
 Strainer/Butt: MCS70A/MCS70B  
 Snare Wire: MS20R14S  
 Color: Matte Vintage Maple (MVM)

## SOUNDWORKS STEEL



### DST1055M

Shell: 1.2mm Steel  
Size: 10"x5.5"  
Lug: MSL60S  
Hoop: Triple Flanged Hoop (6 hole)  
Strainer/Butt: MCS70A/MCS70B  
Snare Wire: MS16R10S  
\*Tom bracket is equipped.  
\*MC69 single tom attachment is included.

## SOUNDWORKS STEEL



### DST1465

Shell: 1.2mm Steel  
Size: 14"x6.5"  
Lug: MSL60S  
Hoop: Steel Mighty Hoop (10 hole)  
Strainer/Butt: MCS70A/MCS70B  
Snare Wire: MS20R14S

## METALWORKS



### BST1055MBK

Shell: 1mm Steel  
Size: 10"x5.5"  
Lug: MSL60SBK  
Hoop: Triple Flanged Hoop (6 hole)  
Strainer/Butt: MUS65ABK/MUS60BBK  
Snare Wire: MS16R10S  
\*Tom bracket is equipped.

## METALWORKS



### BST134BK

Shell: 1mm Steel  
Size: 13"x4"  
Lug: MSL-SCPBK  
Hoop: Triple Flanged Hoop (6 hole)  
Strainer/Butt: MUS65ABK/MUS60BBK  
Snare Wire: MS20R13S

## METALWORKS



### BST1455BK

Shell: 1mm Steel  
Size: 14"x5.5"  
Lug: MSL60SBK  
Hoop: Triple Flanged Hoop (8 hole)  
Strainer/Butt: MUS65ABK/MUS60BBK  
Snare Wire: MS20R14S

## METALWORKS



### BST1465BK

Shell: 1mm Steel  
Size: 14"x6.5"  
Lug: MSL60SBK  
Hoop: Triple Flanged Hoop (8 hole)  
Strainer/Butt: MUS65ABK/MUS60BBK  
Snare Wire: MS20R14S

## METALWORKS "EFFECT" MINI-TYMP SNARE DRUMS



### BST63MBK

Shell: 1mm Steel  
Size: 6"x3"  
Lug: MSL80TBK  
Hoop: Triple Flanged Hoop (4 hole)  
Snare Wire: Mod Tone System w/ Snare Wire  
\*Tom bracket is equipped.  
\*MC69 single tom attachment is included.

## METALWORKS "EFFECT" MINI-TYMP SNARE DRUMS



### BST83MBK

Shell: 1mm Steel  
Size: 8"x3"  
Lug: MSL80TBK  
Hoop: Triple Flanged Hoop (4 hole)  
Snare Wire: Mod Tone System w/ Snare Wire  
\*Tom bracket is equipped.  
\*MC69 single tom attachment is included.

## METALWORKS "EFFECT" MINI-TYMP SNARE DRUMS



### BST103MBK

Shell: 1mm Steel  
Size: 10"x3"  
Lug: MSL80TBK  
Hoop: Triple Flanged Hoop (6 hole)  
Snare Wire: Mod Tone System w/ Snare Wire  
\*Tom bracket is equipped.  
\*MC69 single tom attachment is included.

## METALWORKS "EFFECT" MINI-TYMP SNARE DRUMS



### BST143MBK

Shell: 1mm Steel  
Size: 14"x3"  
Lug: MSL80TBK  
Hoop: Triple Flanged Hoop (6 hole)  
Snare Wire: Mod Tone System w/ Snare Wire  
\*Tom bracket is equipped.  
\*MC69 single tom attachment is included.

**NEW**

# SIGNATURE PALETTE SNARE DRUMS

MADE IN JAPAN

## KENNY ARONOFF



### KA1465

Trackmaster  
Shell: 1mm Brass  
Size: 14"x6.5"  
Lug: MSL35 (Nickel)  
Hoop: Brass Mighty Hoop (10 hole)  
Strainer/Butt: MUS80A/MUS80B (Nickel)  
Snare Wire: MS20SN14S



### KA145N

Trackmaster  
Shell: 1mm Brass  
Size: 14"x5"  
Lug: MSL35  
Hoop: Die-Cast Hoop (10 hole)  
Strainer/Butt: MUS80A/MUS80B  
Snare Wire: MS20SN14S

## RONALD BRUNER JR.



### RB1455

Shell: 6mm 6ply Walnut + 1mm Steel  
Size: 14"x5.5"  
Lug: MSL-SCT in Matte Black Finish  
Hoop: Die-Cast Hoop (10 hole) in Matte Black Finish  
Strainer/Butt: MLS50A/MLS50B in Matte Black Finish  
Snare Wire: MS20RL14C



## SIGNATURE PALETTE -PETER ERSKINE



### PE1445

Shell: 6mm, 4ply Spruce + 2 inner ply Maple  
Size: 14"x4.5"  
Lug: STAR Tube Lug  
Hoop: 2.3mm Sound Arc Hoop (8 Hole)  
Strainer/Butt: MLSS0A / MLS50B  
Snare Wire: MS20RL14C

NEW



### PE106M

Shell: 10mm, 12pcs Stave Ash  
Size: 10"x6"  
Lug: MSL90S  
Hoop: Die-Cast Hoop (6 Hole)  
Strainer/Butt: MLSS0A / MLS50B  
Snare Wire: MS20SN10S  
Super Resonant Mounting System Equipped





## SIMON PHILLIPS



### SP125H

The Pageant  
Shell: 6mm, 7ply Figured Maple w/ 6mm Sound Focus Rings  
Size: 12"x5"  
Lug: MSL35H  
Hoop: Die-Cast Hoop (6 hole, Brushed Nickel)  
Strainer/Butt: MUS80AH/MUS80BH  
Snare Wire: MS20S-12S



### SP1455H

The Gladiator  
Shell: 1mm Bronze  
Size: 14"x5.5"  
Lug: MSL35H  
Hoop: Brass Mighty Hoop (10 hole, Brushed Nickel)  
Strainer/Butt: MUS80AH/MUS80BH  
Snare Wire: MS20S-S



### SP1465H

The Monarch  
Shell: 6mm, 3ply Figured Maple/3ply Bubinga/2ply Maple w/ 6mm Sound Focus Rings  
Size: 14"x6.5"  
Lug: MSL-SCTH  
Hoop: Customized Brass Mighty Hoop (8 hole, Brushed Nickel)  
Strainer/Butt: MUS80AH/MUS80BH  
Snare Wire: MS20S-S

## MIKE PORTNOY



### MP125ST

Shell: 1mm Steel (Hammered Matte Black)  
Size: 12"x5"  
Lug: MSL-SCT  
Hoop: Die-Cast Hoop (6 hole)  
Strainer/Butt: MCS100A/MCS70B  
Snare Wire: MS20SN12S



### MP1455ST

Shell: 1mm Steel (Hammered Matte Black)  
Size: 14"x5.5"  
Lug: MSL-SCT  
Hoop: Die-Cast Hoop (8 hole)  
Strainer/Butt: MCS100A/MCS70B  
Snare Wire: MS20SN14S



### MP1455BU

Shell: 8mm, 9ply Bubinga  
Size: 14"x5.5"  
Lug: MSL-SCT  
Hoop: Die-Cast Hoop (8 hole)  
Strainer/Butt: MCS100A/MCS70B  
Snare Wire: MS20SN14S



## LARS ULRICH



### LU1465N

Shell: 3mm Diamond Plate Steel  
Size: 14"x6.5"  
Lug: MSL35  
Hoop: Die-Cast Hoop (10 hole)  
Strainer/Butt: MUS80A/MUS80B  
Snare Wire: MS20SN14S



## STEWART COPELAND

### SC145

Shell: 1.5mm Brass | Chrome Finish  
Size: 14"x5"  
Lug: MSL35  
Hoop: Die-Cast Hoop (10 hole, batter side)/steel  
Mighty Hoop (10 hole, snare side)  
Strainer/Butt: MUS80A/MUS80B  
Snare Wire: MS20SN14S

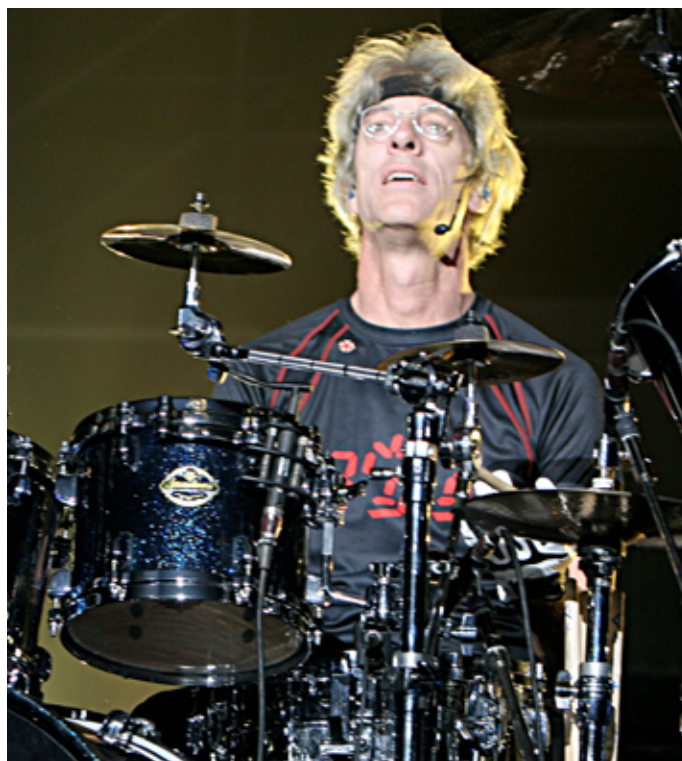

## CHARLIE BENANTE

### CB1465

Shell: 1.2mm Stainless Steel  
Size: 14"x6.5"  
Lug: MSL35BN  
Hoop: Die-Cast Hoop (10 hole)  
Strainer/Butt: MUS80ABN/MUS80BBN  
Snare Wire: MS20SN14S



## JOHN TEMPESTA



### JT147

Shell: 2mm Brass  
Size: 14"x7"  
Lug: MSL-SCTBN  
Hoop: Die-Cast Hoop (10 hole)  
Strainer/Butt: MUS80ABN/MUS80BBN  
Snare Wire: MS42R14S



# DRUM PEDALS

Our Iron Cobra pedals have long been praised for being smooth, reliable, and independently adjustable. Iron Cobra pedals are offered in the high end 900 series as well as the standard 600 and 200 models. Speed Cobra 910 and 310 drum pedals feature a longer footboard for a lighter, quicker feel. Our drum pedal range is designed to fit the needs of every drummer.



CHRISTIAN BASS | HEAVEN SHALL BURN

## DYNA-SYNC TWIN PEDAL



### HPDS1TW

- Optimized Transmission Design
- Dual Linkage
- Slidable Cam
- Footboard Angle Adjustment
- Dyna Beater
- Swivel Spring Tight
- Speedo-Ring
- Oiles Bearing Hinge
- Para-Clamp II Pro
- Sync-Coil
- Hinge Guard Block
- Hardshell Carrying Case

## DYNA-SYNC SINGLE PEDAL



### HPDS1

- Optimized Transmission Design
- Dual Linkage
- Slidable Cam
- Footboard Angle Adjustment
- Dyna Beater
- Swivel Spring Tight
- Speedo-Ring
- Oiles Bearing Hinge
- Para-Clamp II Pro
- Sync-Coil
- Hinge Guard Block
- Hardshell Carrying Case

## SPEED COBRA 910 SINGLE PEDAL



### HP910LN

- Long Footboard
- Recessed Setting
- Rolling Glide LiteSprocket Cam
- Accu-Strike Cobra Beater
- Swivel Spring Tight
- Super Stabilizer Design
- Para-Clamp II Pro
- Cobra Coil
- Hinge Guard Block
- Hardshell Carrying Case



## SPEED COBRA 910 TWIN PEDAL



### HP910LWN

- Long Footboard
- Recessed Setting
- Rolling Glide LiteSprocket Cam
- Accu-Strike Cobra Beater
- Swivel Spring Tight
- Super Stabilizer Design
- Para-Clamp II Pro
- Cobra Coil
- Hinge Guard Block
- Hardshell Carrying Case

## SPEED COBRA 910 TWIN PEDAL



### HP910LWLN

- Left-Footed
- Long Footboard
- Recessed Setting
- Rolling Glide LiteSprocket Cam
- Accu-Strike Cobra Beater
- Swivel Spring Tight
- Super Stabilizer Design
- Para-Clamp II Pro
- Cobra Coil
- Hinge Guard Block
- Hardshell Carrying Case



## IRON COBRA 900 SINGLE PEDAL -POWER GLIDE-



### HP900PN

- Power Glide LiteSprocket Cam
- Power-Strike Cobra Beater
- Swivel Spring Tight
- Super Stabilizer Design
- Para-Clamp II Pro
- Cobra Coil
- Hinge Guard Block
- Hardshell Carrying Case

## IRON COBRA 900 TWIN PEDAL -POWER GLIDE-



### HP900PWN

- Power Glide LiteSprocket Cam
- Power-Strike Cobra Beater
- Swivel Spring Tight
- Super Stabilizer Design
- Para-Clamp II Pro
- Cobra Coil
- Hinge Guard Block
- Hardshell Carrying Case

## IRON COBRA 900 TWIN PEDAL -POWER GLIDE-



### HP900PWLN

- Left-Footed
- Power Glide LiteSprocket Cam
- Power-Strike Cobra Beater
- Swivel Spring Tight
- Super Stabilizer Design
- Para-Clamp II Pro
- Cobra Coil
- Hinge Guard Block
- Hardshell Carrying Case

## IRON COBRA 900 TWIN PEDAL -ROLLING GLIDE-



### HP900RWN

- Rolling Glide LiteSprocket Cam
- Power-Strike Cobra Beater
- Swivel Spring Tight
- Super Stabilizer Design
- Para-Clamp II Pro
- Cobra Coil
- Hinge Guard Block
- Hardshell Carrying Case

## IRON COBRA 900 SINGLE PEDAL -ROLLING GLIDE-



### HP900RN

- Rolling Glide LiteSprocket Cam
- Power-Strike Cobra Beater
- Swivel Spring Tight
- Super Stabilizer Design
- Para-Clamp II Pro
- Cobra Coil
- Hinge Guard Block
- Hardshell Carrying Case



## IRON COBRA 600 SINGLE PEDAL -DUO GLIDE-



### HP600D

- Duo Glide
- Double Chain Drive
- Speedo-Ring
- Para-Clamp
- Spring Tension Adjustment
- Beater Angle Adjustment
- Dual Sided Beater

## IRON COBRA 600 TWIN PEDAL -DUO GLIDE-



### HP600DTW

- Duo Glide
- Double Chain Drive
- Speedo-Ring
- Para-Clamp
- Spring Tension Adjustment
- Beater Angle Adjustment
- Dual Sided Beater



## SPEED COBRA 310 TWIN PEDAL



### HP310LW

- Long Footboard
- Recessed Setting
- Rolling Glide LiteSprocket
- Double Chain Drive
- Spring Tension Adjustment
- Beater Angle Adjustment
- Dual Sided Beater

## SPEED COBRA 310 SINGLE PEDAL



### HP310L

- Long Footboard
- Recessed Setting
- Rolling Glide LiteSprocket
- Double Chain Drive
- Spring Tension Adjustment
- Beater Angle Adjustment
- Dual Sided Beater

## IRON COBRA 200 SINGLE PEDAL



### HP200P

- Power Glide
- Spring Tension Adjustment
- Beater Angle Adjustment
- Dual Sided Beater

## IRON COBRA 200 TWIN PEDAL



### HP200PTW

- Power Glide
- Spring Tension Adjustment
- Beater Angle Adjustment
- Dual Sided Beater



ANDI BRÜGGE | BROILERS

## STANDARD SINGLE PEDAL



### HP30

- Power Glide
- Spring Tension Adjustment
- Beater Angle Adjustment
- Dual Sided Beater

## IRON COBRA 200 TWIN PEDAL



### HP200PTWL

- Left-Footed
- Power Glide
- Spring Tension Adjustment
- Beater Angle Adjustment
- Dual Sided Beater

## THE CLASSIC PEDAL



### HP50

- Center Strike Height Adjust
- Easy Access Spring Adjustment
- The Classic Beater
- Smooth Surface Footboard
- Individual Adjustment of Beater & Footboard Angle
- Easy-Tight Hoop Clamp
- Compact Folding Design

## TWIN PEDAL ATTACHMENT

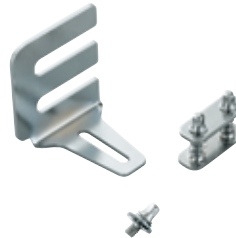

### TPA90

Specially designed attachment to connect Speed Cobra 910 and Iron Cobra 900 series pedals with Speed Cobra 910 and Iron Cobra 900 series Hi-hat stands.



MAX ZIMMER | ITCHY

# HI-HAT STANDS

In addition to bass drum pedals, we offer various hi-hat stands including our high end Dyna-Sync, Iron Cobra & Speed Cobra models as well as our standard Stage Master models.

## DYNA-SYNC HI-HAT STAND



### HHDS1

- Direct Drive Action
- Spring Damper for Reducing Noise
- Quick-Set Hi-Hat Clutch
- 6-way Tension Adjustment
- Footboard Angle Adjustment
- Bigger Rubber Feet w/Duo-Spike
- Weight: 5.2kg (11.7lbs)
- Height Adjustment Range:  
745mm-960mm (29 3/8" - 37 3/4") (Standard Rod) /  
745mm-810mm (29 3/8" - 31 7/8") (Short Rod)

## SPEED COBRA 910 HI-HAT STAND - LEVER GLIDE



### HH915D

- Spring Seat
- Quick-Set Hi-Hat Clutch
- 6-way Tension Adjustment
- Bigger Rubber Feet w/Duo-Spike
- Weight: 5.2kg (11.7lbs)
- Height Adjustment Range:  
745mm-960mm (29 3/8" - 37 3/4") (Standard Rod) /  
745mm-810mm (29 3/8" - 31 7/8") (Short Rod)

## IRON COBRA 900 HI-HAT STAND -LEVER GLIDE



### HH905D

- Spring Seat
- Quick-Set Hi-Hat Clutch
- 6-way Tension Adjustment
- Bigger Rubber Feet w/Duo-Spike
- Weight: 5.2kg (11.7lbs)
- Height Adjustment Range:  
745mm-960mm (29 3/8" - 37 3/4") (Standard Rod) /  
745mm-810mm (29 3/8" - 31 7/8") (Short Rod)

## IRON COBRA 900 HI-HAT STAND -VELO GLIDE



### HH805D

- Spring Seat
- Quick-Set Hi-Hat Clutch
- 6-way Tension Adjustment
- Bigger Rubber Feet w/Duo-Spike
- Weight: 5.2kg (11.7lbs)
- Height Adjustment Range:  
745mm-960mm (29 3/8" - 37 3/4") (Standard Rod) /  
745mm-810mm (29 3/8" - 31 7/8") (Short Rod)

## IRON COBRA 900 REMOTE HI-HAT STAND



### HH905RH

- JAGWIRE™ Triple-Layered Ultra-Smooth Cable
- Quick-Set Hi-Hat Clutch
- Lever Glide
- 6-way Tension Adjustment
- MC66 Universal Clamp
- Ratchet Arm (Φ12mm, Arm Length: 200mm)
- Dual Leg
- Cable Holders (x 6)
- Carrying Bag
- Weight: 8.1kg (17lbs)

## IRON COBRA 600 HI-HAT STAND



### HH605

- Spring Seat
- Swing Lock Clutch
- 6-way Tension Adjustment
- Swivel Foot
- Direct Pull Action
- Footboard Angle Adjustment
- Weight: 4.3kg (9.7lbs)
- Height Adjustment Range: 710mm-930mm (28" - 36 5/8")

## SPEED COBRA 310 HI-HAT STAND



### HH315D

- Dual Leg
- 28.6mm Diameter Base Section Tubing
- Security Clutch
- 6-way Tension Adjustment
- Swivel Foot
- Direct Pull Action
- Weight: 3.9kg (8.9lbs)
- Height Adjustment Range: 710mm-930mm (28" - 36 5/8")

## IRON COBRA 200 HI-HAT STAND



### HH205

- Double Braced Legs
- 5-way Tension Adjustment
- Swivel Foot
- Direct Pull Action
- Non-Loosening Tension Rod
- Toe Guard
- Security Clutch
- Weight: 3.8kg (8.6lbs)
- Height Adjustment Range: 670mm-930mm (26 3/8" - 36 5/8")





JÜRGEN 'VENTOR' REIL | KREATOR

## IRON COBRA 200 HI-HAT STAND



### HH205S

- Single Braced Legs
- 5-way Tension Adjustment
- Swivel Foot
- Direct Pull Action
- Non-Loosening Tension Rod
- Toe Guard
- Security Clutch
- Weight: 3.1kg (6.8lbs)
- Height Adjustment Range: 670mm-930mm (26 3/8" - 36 5/8")

## STAGE MASTER HI-HAT STAND



### HH45WN

- Double Braced Legs
- Swivel Foot
- Direct Pull Action
- Non-Loosening Tension Rod
- Toe Guard
- Security Clutch
- Weight: 3.4kg (7.6lbs)
- Height Adjustment Range: 670mm-930mm (26 3/8" - 36 5/8")

## STAGE MASTER HI-HAT STAND



### HH45SN

- Single Braced Legs
- Swivel Foot
- Direct Pull Action
- Non-Loosening Tension Rod
- Toe Guard
- Security Clutch
- Weight: 3.0kg (6.7lbs)
- Height Adjustment Range: 670mm-930mm (26 3/8" - 36 5/8")

## THE CLASSIC HI-HAT STAND



### HH55F

- Single Braced Flat Base Tripod Legs
- Individual Adjustment of Spring Tension & Footboard Angle
- Knurling on Base Pipe
- Memory Lock
- Weight: 2.3kg (5.1 lbs)
- Height Adjustment Range: 650mm-950mm (24 5/8" - 37 3/8")
- Storage size: 500mm (19 11/16") (upper section) / 600mm (23 5/8") (lower section)



TOBIAS SCHULER | DER WEG EINER FREIHEIT

# DRUM THRONES

Being comfortable on your drum set is one of the most important aspects of drumming, making the drum throne a vital yet often overlooked piece of equipment. Our ergonomic 1st Chair Drum Thrones have many original TAMA features to guarantee comfort, stability and quick as well as easy setup.

## 1ST CHAIR ROUND RIDER XL DRUM THRONE -CLOTH TOP



### HT850BC

Round Rider XL "Cloth Top" Seat  
 -15" Diameter, 130mm (5 1/8") Thick Round Seat  
 -HYDRAULIX  
 -Seat Lock  
 -Oversized Rubber Feet  
 -Foot Life  
 -Weight: 6.0kg (13.3lbs)  
 -Height Adjustment Range: 515mm - 695mm (21 1/4" - 27 3/8")

## 1ST CHAIR ROUND RIDER XL DRUM THRONE



### HT830R

Round Rider XL Seat  
 -15" Diameter, 130mm (5 1/8") Thick Round Seat  
 -1st Chair Height Adjustment  
 -Seat Lock  
 -Glide-Tite Grip Joint  
 -Rocklok  
 -Oversized Rubber Feet  
 -Foot Life  
 -Weight: 6.0kg (13.3lbs)  
 -Height Adjustment Range: 515mm - 670mm (21 1/4" - 26 3/8")

## 1ST CHAIR ROUND RIDER XL DRUM THRONE



### HT830B

Round Rider XL Seat  
 -15" Diameter, 130mm (5 1/8") Thick Round Seat  
 -1st Chair Height Adjustment  
 -Seat Lock  
 -Glide-Tite Grip Joint  
 -Rocklok  
 -Oversized Rubber Feet  
 -Foot Life  
 -Weight: 6.0kg (13.3lbs)  
 -Height Adjustment Range: 515mm - 670mm (21 1/4" - 26 3/8")

## 1ST CHAIR ERGO-RIDER DRUM THRONE -CLOTH TOP



### HT750BC

Ergo-Rider "Cloth Top" Seat  
 -HYDRAULIX  
 -Seat Lock  
 -Oversized Rubber Feet  
 -Foot Life  
 -Weight: 6.1kg (13.7lbs)  
 Height Adjustment Range: 505mm - 685mm (19 7/8" - 27")

## 1ST CHAIR ERGO-RIDER DRUM THRONE



### HT730B

Ergo-Rider Seat  
 -1st Chair Height Adjustment  
 -Seat Lock  
 -Glide-Tite Grip Joint  
 -Rocklok  
 -Oversized Rubber Feet  
 -Foot Life  
 -Weight: 6.1kg (13.7lbs)  
 -Height Adjustment Range: 505mm - 660mm (19 7/8" - 26")

## 1ST CHAIR ERGO-RIDER DRUM THRONE -QUARTET



### HT741B

Ergo-Rider Seat  
 -1st Chair Height Adjustment  
 -Seat Lock  
 -Backrest  
 -Glide-Tite Grip Joint  
 -Rocklok  
 -Oversized Rubber Feet  
 -Foot Life  
 -Weight: 9.4kg (20.1lbs)  
 -Height Adjustment Range: 515mm - 665mm (20 1/4" - 26 3/6")

## 1ST CHAIR GLIDE RIDER DRUM THRONE -CLOTH TOP



### HT550BCN

Glide Rider "Cloth Top" Seat  
 -HYDRAULIX  
 -Seat Lock  
 -Glide-Tite Grip Joint  
 -Rocklok  
 -Oversized Rubber Feet  
 -Foot Life  
 -Weight: 5.9kg (13lbs)  
 -Height Adjustment Range: 470mm - 650mm (18 1/2" - 24 5/8")

## 1ST CHAIR GLIDE RIDER DRUM THRONE -CLOTH TOP



### HT530BCN

Glide Rider "Cloth Top" Seat  
 -1st Chair Height Adjustment  
 -Seat Lock  
 -Glide-Tite Grip Joint  
 -Rocklok  
 -Oversized Rubber Feet  
 -Foot Life  
 -Weight: 5.9kg (13lbs)  
 -Height Adjustment Range: 470mm - 650mm (18 1/2" - 24 5/8")



SASCHA MADSEN | MADSEN

### 1ST CHAIR WIDE RIDER DRUM THRONE -CLOTH TOP



#### HT530BC

- Wide Rider "Cloth Top" Seat
- 1st Chair Height Adjustment
- Seat Lock
- Glide-Tite Grip Joint
- Rocklok
- Oversized Rubber Feet
- Foot Life
- Weight: 6.0kg (13.3lbs)
- Height Adjustment Range: 485mm - 640mm (19" - 25 3/16")

### 1ST CHAIR WIDE RIDER DRUM THRONE



#### HT530B

- Wide Rider Seat
- 1st Chair Height Adjustment
- Seat Lock
- Glide-Tite Grip Joint
- Rocklok
- Oversized Rubber Feet
- Foot Life
- Weight: 6.0kg (13.3lbs)
- Height Adjustment Range: 485mm - 640mm (19" - 25 3/16")

### 1ST CHAIR ROUND RIDER DRUM THRONE -CLOTH TOP



#### HT430BC

- Round Rider "Cloth Top" Seat
- 14" Diameter, 120mm (4 3/4") Thick Round Seat
- 1st Chair Height Adjustment
- Seat Link
- Rocklok
- Foot Life
- Weight: 5.3kg (11.1lbs)
- Height Adjustment Range: 485mm - 655mm (19" - 25 3/4")

### 1ST CHAIR ROUND RIDER DRUM THRONE



#### HT430B

- Round Rider Seat
- 14" Diameter, 120mm (4 3/4") Thick Round Seat
- 1st Chair Height Adjustment
- Seat Link
- Rocklok
- Foot Life
- Weight: 5.3kg (11.1lbs)
- Height Adjustment Range: 485mm - 655mm (19" - 25 3/4")

### 1ST CHAIR SADDLE-TYPE DRUM THRONE



#### HT250

- Saddle-Type Seat
- 1st Chair Height Adjustment
- Glide-Tite Grip Joint
- Rocklok
- Foot Life
- Weight: 4.05kg (8.9lbs)
- Height Adjustment Range: 425mm - 625mm (16 3/4" - 24 1/2")

### 1ST CHAIR ROUNDED TYPE DRUM THRONE



#### HT230

- Rounded Seat
- 1st Chair Height Adjustment
- Glide-Tite Grip Joint
- Rocklok
- Foot Life
- Weight: 4.0kg (8.8lbs)
- Height Adjustment Range: 460mm - 660mm (18" - 26")

### STANDARD DRUM THRONE



#### HT130

- 13" Diameter, 90mm (3 1/2") Thick Round Seat
- Double Braced Legs
- Weight: 3.4kg (7.7lbs)
- Height Adjustment Range: 445mm - 620mm (17 1/2" - 24 7/16")



# SNARE STANDS

Our STAR snare stand has several unique features which provide the ultimate solution for a flexible and stable snare drum setup. Our Roadpro stands now have greater stability, in addition to Quick-Set universal tilters.

## STAR HARDWARE SNARE STAND



### HS100W

- For 12" to 15" Diameter Snare Drums
- 28.6mm Diameter Base Section Tubing
- Cradle-Hold Snare Basket
- Glide-Tite Grip Joint
- True-Sound Insulation Mute
- Oversized Rubber Feet with Retractable Spike
- Weight: 3.9kg (8.9lbs)
- Height Adjustment Range: 400mm - 600mm (15 3/4" - 23 5/8")

## ROADPRO SNARE STAND



### HS800W

- For 12" to 15" Diameter Snare Drums
- 28.6mm Diameter Base Section Tubing
- Omni-Ball Tilter
- Swiveling Basket
- Glide-Tite Grip Joint
- Double Braced Legs
- Weight: 3.4kg (7.7lbs)
- Height Adjustment Range: 495mm - 665mm (19 1/2" - 26 3/8")

## ROADPRO SNARE STAND



### HS80W

- For 12" to 15" Diameter Snare Drums
- 28.6mm Diameter Base Section Tubing
- Quick-Set Tilter
- Swiveling Basket
- Glide-Tite Grip Joint
- Double Braced Legs
- Weight: 3.2kg (7lbs)
- Height Adjustment Range: 495mm - 640mm (19 1/2" - 25 3/16")

## ROADPRO SNARE STAND



### HS80PW

- For 10" to 12" Diameter Snare Drums
- 28.6mm Diameter Base Section Tubing
- Quick-Set Tilter
- Swiveling Basket
- Glide-Tite Grip Joint
- Double Braced Legs
- Weight: 3.2kg (7lbs)
- Height Adjustment Range: 465mm - 610mm (18 5/16" - 24")

## ROADPRO SNARE STAND



### HS80LOW

- For 12" to 15" Diameter Snare Drums
- 28.6mm Diameter Base Section Tubing
- Low Position Setting Basket
- Quick-Set Tilter
- Glide-Tite Grip Joint
- Double Braced Legs
- Weight: 3.3kg (7.4lbs)
- Height Adjustment Range: 385mm - 530mm (15 3/16" - 20 7/8")

## 60 SERIES SNARE STAND



### HS60W

- For 12" to 15" Diameter Snare Drums
- 25.4mm Diameter Base Section Tubing
- Quick-Set Tilter
- Swiveling Basket
- Double Braced Legs
- Weight: 2.6kg (5.1lbs)
- Height Adjustment Range: 470mm - 600mm (18 1/2" - 23 5/8")



STEFAN GÜNTHER-MARTENS | ASP

## STAGE MASTER SNARE STAND



### HS40WN

- For 12" to 15" Diameter Snare Drums
- 25.4mm Diameter Base Section Tubing
- Universal Gearless Tilter
- Swiveling Basket
- Double Braced Legs
- Weight: 2.6kg (5.11lbs)
- Height Adjustment Range: 470mm - 630mm (18 1/2" - 24 13/16")

## STAGE MASTER SNARE STAND



### HS40SN

- For 12" to 15" Diameter Snare Drums
- 25.4mm Diameter Base Section Tubing
- Universal Gearless Tilter
- Swiveling Basket
- Single Braced Legs
- Weight: 2.5kg (5.8lbs)
- Height Adjustment Range: 470mm - 630mm (18 1/2" - 24 13/16")



FLO KÖNIG | CRO & 9MS



CHRISTIN NEDDENS | NDR BIG BAND & HELGE

## STAGE MASTER SNARE STAND



### HS40LOWN

- For 12" to 15" Diameter Snare Drums
- 25.4mm Diameter Base Section Tubing
- Low Position Setting Basket
- Universal Gearless Tilter
- Double Braced Legs
- Weight: 2.7kg (5.15lbs)
- Height Adjustment Range: 370mm - 530mm (14 9/16" - 20 7/8")

## THE CLASSIC SNARE STAND



### HS50S

- For 12" to 15" Diameter Snare Drums
- 19.1mm Diameter Base Section Tubing
- Single Braced Tripod Legs
- Classic Style Basket
- Double Braced Arms
- Gearless Tilter
- Memory Lock
- Weight: 1.7kg (3.11lbs)
- Height Adjustment Range: 390mm-580mm (15 3/8" - 22 7/8")
- Storage size: 600mm (23 5/8")

# CYMBAL STANDS

The TAMA STAR Hardware cymbal stand is incredibly flexible with several groundbreaking adjustment features. The Roadpro cymbal stands benefit from greater stability, and include the same great Quick-Set Tilter and Quick-Set Cymbal Mates.

## STAR HARDWARE CYMBAL STAND



### HC103BW

- 28.6mm Diameter Base Section Tubing
- Orbital Quick-Tite Cymbal/BoomTilter
- Glide-Tite Grip Joint
- True-Sound Insulation Mute
- Ring-True Cymbal Felt
- Boom Arm Length: 450mm (17 3/4")
- Weight: 6.1kg (13.7lbs)
- Height Adjustment Range: 890mm - 2,090mm (35" - 82 1/4")

## ROADPRO CYMBAL STAND



### HC84BW

- 28.6mm Diameter Base Section Tubing
- Quick-Set Tilter
- Quick-Set Cymbal Mate
- Boom/Straight Convertible Tilter
- Glide-Tite Grip Joint
- Detachable Counter Weight
- Boom Arm Length : 688mm (27 3/32")
- Weight : 6.2kg (13.10lbs)
- Height Adjustment Range: 820mm - 2,200mm (32 1/4" - 86 5/8")

## ROADPRO CYMBAL STAND



### HC83BW

- 28.6mm Diameter Base Section Tubing
- Quick-Set Tilter
- Quick-Set Cymbal Mate
- Boom/Straight Convertible Tilter
- Glide-Tite Grip Joint
- Double Braced Legs
- Boom Arm Length: 450mm (17 3/4")
- Weight: 5.0kg (11lbs)
- Height Adjustment Range: 820mm - 2,100mm (32 1/4" - 82 5/8")

## ROADPRO CYMBAL STAND



### HC82W

- 28.6mm Diameter Base Section Tubing
- Quick-Set Tilter
- Quick-Set Cymbal Mate
- Glide-Tite Grip Joint
- Double Braced Legs
- Weight: 4.2kg (9.4lbs)
- Height Adjustment Range: 740mm - 1,610mm (31 1/8" - 72 7/8")

## ROADPRO LIGHT CYMBAL STAND



### HC83BLS

- 25.4mm Diameter Base Section Tubing
- Quick-Set Tilter
- Quick-Set Cymbal Mate
- Boom/Straight Convertible Tilter
- Glide-Tite Grip Joint
- Single Braced Legs
- Boom Arm Length: 400mm (15 3/4")
- Weight: 3.8kg (8.6lbs)
- Height Adjustment Range: 790mm - 1,850mm (31 1/8" - 72 7/8")

## ROADPRO LIGHT CYMBAL STAND



### HC82LS

- 25.4mm Diameter Base Section Tubing
- Quick-Set Tilter
- Quick-Set Cymbal Mate
- Glide-Tite Grip Joint
- Single Braced Legs
- Weight: 3.1kg (6.13lbs)
- Height Adjustment Range: 710mm - 1,410mm (28" - 55 1/2")

## 60 SERIES CYMBAL STAND



### HC63BW

- 25.4mm Diameter Base Section Tubing
- Quick-Set Tilter
- Boom/Straight Convertible Tilter
- Double Braced Legs
- Boom Arm Length: 400mm (15 3/4")
- Weight: 3.9kg (8.9lbs)
- Height Adjustment Range: 850mm - 2,010mm (33 1/2" - 79 1/8")

## 60 SERIES CYMBAL STAND



### HC62W

- 25.4mm Diameter Base Section Tubing
- Quick-Set Tilter
- Double Braced Legs
- Weight: 3.2kg (7.1 lbs)
- Height Adjustment Range: 780mm - 1,620mm (30 3/4" - 63 3/4")



WILL BELGART | DIE ORSONS

## STAGE MASTER CYMBAL STAND



### HC43BSN

- 25.4mm Diameter Base Section Tubing
- Fine Gear Tilter
- Quick-Set Cymbal Mate
- Boom/Straight Convertible Tilter
- Single Braced Legs
- Boom Arm Length: 400mm (15 3/4")
- Weight: 3.4kg (7.7lbs)
- Height Adjustment Range: 760mm - 1,800mm (30" - 70 13/16")

## STAGE MASTER CYMBAL STAND



### HC42SN

- 25.4mm Diameter Base Section Tubing
- Fine Gear Tilter
- Quick-Set Cymbal Mate
- Single Braced Legs
- Weight: 2.7kg (5.15lbs)
- Height Adjustment Range: 690mm - 1,420mm (27 1/8" - 55 15/16")

## STAGE MASTER CYMBAL STAND



### HC43BWN

- 25.4mm Diameter Base Section Tubing
- Fine Gear Tilter
- Quick-Set Cymbal Mate
- Boom/Straight Convertible Tilter
- Double Braced Legs
- Boom Arm Length: 400mm (15 3/4")
- Weight: 3.4kg (7.5lbs)
- Height Adjustment Range: 760mm - 1,800mm (30" - 70 13/16")

## STAGE MASTER CYMBAL STAND



### HC42WN

- 25.4mm Diameter Base Section Tubing
- Fine Gear Tilter
- Quick-Set Cymbal Mate
- Double Braced Legs
- Weight: 2.9kg (6.6lbs)
- Height Adjustment Range: 690mm - 1,420mm (27 1/8" - 55 15/16")

## THE CLASSIC CYMBAL STAND



### HC52F

- 19.1mm Diameter Base Section Tubing
- Flat Base Leg Design
- 9mm Diameter Solid Upper Portion
- Fine Gear Tilter
- Compact Folding Design (580mm 22 27/32")
- Weight 1.48kg (3.2lbs)
- Height Adjustment Range: 590mm - 1,300mm (23 1/4" - 51 3/16")



GERWIN EISENHAUER | TRIO ELF

# TOM STANDS & TOM HOLDERS

TAMA's tom stands and tom holders feature our original Omni-Ball system which allows each tom to be held securely in place. You can position the drum at virtually any angle simply by loosening one T-nut.

## STAR HARDWARE COMBINATION STAND



### HTC107W

- 28.6mm Diameter Base Section Tubing
- Swivel-Wing Tom Holder
- Orbital Quick-Tite Cymbal Tilter
- Orbital Quick-Tite Boom Tilter
- Glide-Tite Grip Joint
- True-Sound Insulation Mute
- Ring-True Cymbal Felt
- Boom Arm Length: 300mm (11 3/4")
- Weight: 7.2kg (15.13lbs)

## STAR HARDWARE DOUBLE TOM STAND



### HTW109W

- 28.6mm Diameter Base Section Tubing
- Swivel-Wing Tom Holder
- Stilt System
- Glide-Tite Grip Joint
- Extra Heavy Double Braced Legs
- Weight: 6.0kg (13lbs)

## STAR HARDWARE SINGLE TOM STAND



### HTS108W

- For up to 10" Depth Tom Tom
- 28.6mm Diameter Base Section Tubing
- Omni-Ball Tilter
- Glide-Tite Grip Joint
- True-Sound Insulation Mute
- Extra Heavy Double Braced Legs
- Oversized Rubber Feet with Retractable Spike
- Weight: 4.3kg (9.7lbs)

## ROADPRO COMBINATION STAND



### HTC807W

- 28.6mm Diameter Base Section Tubing
- Omni-Ball Tom Angle Adjustment / Movable Tom Positioning
- Quick-Set Tilter
- Quick-Set Cymbal Mate
- Glide-Tite Grip Joint
- Double Braced Legs
- Boom Arm Length: 300mm (11 3/4")
- Weight: 5.4kg (11.14lbs)

## ROADPRO COMBINATION STAND



### HTC87W

- 28.6mm Diameter Base Section Tubing
- Omni-Ball Tom Angle Adjustment
- Quick-Set Tilter
- Quick-Set Cymbal Mate
- Glide-Tite Grip Joint
- Double Braced Legs
- Boom Arm Length: 300mm (11 3/4")
- Weight: 5.5kg (12.2lbs)

## ROADPRO DOUBLE TOM STAND



### HTW839W

- 28.6mm Diameter Base Section Tubing
- Omni-Ball Tom Angle Adjustment
- Stilt System
- Glide-Tite Grip Joint
- Double Braced Legs
- Weight: 5.0kg (11lbs)

## ROADPRO DOUBLE TOM STAND



### HTW849W

- 28.6mm Diameter Base Section Tubing
- Omni-Ball Tom Angle Adjustment
- Glide-Tite Grip Joint
- Double Braced Legs
- Low Profile Tetrapod
- Weight: 5.1kg (11.3lbs)

## STAGE MASTER DOUBLE TOM STAND



### HTW49WN

- 25.4mm Diameter Base Section Tubing
- Omni-Ball Tom Angle Adjustment
- Double Braced Legs
- Weight: 3.6kg (7.14lbs)



## THE CLASSIC TOM STAND



### HTS58F

- For 10" to 14" Diameter Drums
- 19.1mm Diameter Base Section Tubing
- Flat Base Leg Design
- Classic Style Basket
- Memory Lock
- Weight: 1.8kg (3.15lbs)
- Height Adjustment Range: 565mm - 820mm (22 1/4" - 32 1/4")
- Storage size: 600mm (23 5/8") (upper section) / 410mm (16 1/8") (lower section)

## DOUBLE TOM HOLDER



### MTH1000

- 25.4mm Diameter Bass Section Tubing
- Swivel-Wing Tom Holder

MTH1000 (chrome)  
MTH1000BN (black nickel)  
MTH1000U (smoked black nickel)

## DOUBLE TOM HOLDER



### MTH905N

- 25.4mm Diameter Tubing
- Sliding Tom Adjustment

## DOUBLE TOM HOLDER



### MTH600

- 25.4mm Diameter Tubing
- MTH600 (chrome)
- MTH600BN (black nickel)

## SINGLE TOM HOLDER



### MTH1000S

- 25.4mm Diameter Bass Section Tubing
- Swivel-Wing Tom Holder

MTH1000S (chrome)  
MTH1000SBN (black nickel)  
MTH1000SU (smoked black nickel)

## SINGLE TOM HOLDER



### MTH900BS

- 25.4mm Diameter Bass Section Tubing

## SINGLE TOM HOLDER



### MTH900BM

- 25.4mm Diameter Tubing

## DOUBLE TOM HOLDER



### MTH800

- 25.4mm Diameter Tubing

**NEW**



FREDERIC MICHEL | LEA

# HARDWARE KITS

We offer various hardware kit packages to complement any drum sets.

## IRON COBRA 900 HARDWARE KIT



### HG5WN

- HS800W Roadpro Snare Stand
- HC83BW Roadpro Boom Cymbal Stands (x2)
- HH905D Iron Cobra Hi-hat Stand
- HP900PN Iron Cobra Power Glide Single Pedal

## IRON COBRA 600 HARDWARE KIT



### HV5WN

- HS80W Roadpro Snare Stand
- HC83BW Roadpro Boom Cymbal Stands (x2)
- HH605 Iron Cobra 600 Hi-hat Stand
- HP600D Iron Cobra 600 Single Pedal

## IRON COBRA 200 HARDWARE KIT



### HB5W

- HS60W Snare Stand
- HC63BW Boom Cymbal Stands (x2)
- HH205 Iron Cobra 200 Hi-hat Stand
- HP200P Iron Cobra 200 Single Pedal

## STAGE MASTER HARDWARE KIT



### SM5W

- HS40WN Stage Master Snare Stand
- HC43BWN Stage Master Boom Cymbal Stands (x2)
- HH205 Iron Cobra 200 Hi-hat Stand
- HP200P Iron Cobra 200 Single Pedal

## STAGE MASTER HARDWARE KIT



### SM4S

- HS40SN Stage Master Snare Stand
- HC42SN Stage Master Straight Cymbal Stand
- HC43BSN Stage Master Boom Cymbal Stand
- HH45SN Stage Master Hi-hat Stand

## THE CLASSIC STAND HARDWARE KIT



### HC4FB

- HS50S Snare Stand
- HC52F Straight Cymbal Stands (x2)
- HH55F Hi-Hat Stand
- SBH01 Hardware Bag

HG5WN



HV5WN

# POWER TOWER SYSTEM

TAMA's Power Tower System allows you to maintain the same precise set-up time after time. It utilizes 38.1mm stainless round pipes which allow for drums and hardware to be set-up at any angle quickly and easily.

## POWER TOWER SYSTEM BASIC UNIT



### PMD1100M

- 1100mm Curved Pipe x 1pc
- 850mm Straight Pipe w/19.1mm diameter Joint x 2pc
- 40mm x 20mm x 450mm Square Pipe x 2pc
- Leg Joint Bracket x 2pc
- Rubber Foot x 4pc
- Cross Joint Bracket (J30TS) x 2pc
- Multi Holder (J34T) x 2pc
- Memory Lock (A13S) x 4pc

## POWER TOWER SYSTEM ADDITIONAL UNIT



### PMD1100A

- 1100mm Curved Pipe x 1pc
- 850mm Straight Pipe w/19.1mm diameter Joint x 1pc
- 40mm x 20mm x 450mm Square Pipe x 1pc
- Leg Joint Bracket x 1pc
- Rubber Foot x 2pc
- Cross Joint Bracket (J30TS) x 2pc
- Multi Holder (J34T) x 1pc
- Memory Lock (A13S) x 3pc



## POWER TOWER SYSTEM ADDITIONAL UNIT



### PMD900A

- 900mm Curved Pipe x 1pc
- 850mm Straight Pipe w/19.1mm diameter Joint x 1pc
- 40mm x 20mm x 450mm Square Pipe x 1pc
- Leg Joint Bracket x 1pc
- Rubber Foot x 2pc
- Cross Joint Bracket (J30TS) x 2pc
- Multi Holder (J34T) x 1pc
- Memory Lock (A13S) x 3pc

## SINGLE TOM HOLDER



### MTH900BS

A single tom holder with 25.4mm diameter base tube.

## MULTI HOLDER



### J34T

Rack mount for L-rods, tom or cymbal holders. Fits pipes from 10.5mm to 28.6mm in diameter.

## CROSS JOINT BRACKET



### J30TS

90 degree perpendicular pipe clamp that allows horizontal and vertical pipes to be set at an equal height.

## MEMORY LOCK



### A13S

Memory clamp designed specifically for the Power Tower System.

# CLAMPS AND ATTACHMENTS

Back in the 1970's TAMA's original introduction of the multi-clamp was a real revolution in the complex instrument we know as the drum kit. Today, multi-clamps are standard equipment in drums of all brands.

## UNIVERSAL CLAMP

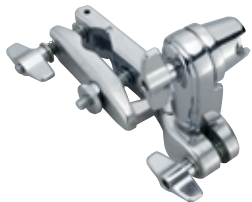

### MC66

One side can hold pipes with diameters from 15.9mm to 28.6mm, while the other side is a ratchet holder that can hold a rod from 9mm to 12mm in diameter at various angles. An excellent clamp for adding an array of new set-up possibilities.

## UNIVERSAL CLAMP



### MC67

The heavier duty version of the MC66. One side holds pipes with diameters from 15.9mm to 28.6mm, while the other side is a ratchet holder that can hold a 12mm to 25.4 mm diameter rod or pipe at various angles.

## UNIVERSAL CLAMP



### MC56

This clamp can be attached to an existing stand pipe that is 15.9mm to 28.9mm in diameter. By attaching a L-Rod or cymbal boom arm that is 9mm to 12mm in diameter, you can easily add a cowbell, woodblock, or cymbal to your drum kit.

## MULTI-CLAMP



### MC61

A basic clamp for connecting stands with pipes from 15.9mm to 28.6mm in diameter with any attachment having a 19.1mm diameter pipe.

## MULTI-CLAMP



### MC62

A double multi-clamp for connecting two pipes from 15.9mm to 28.6mm in diameter. Both sides feature the FastClamp Easy Set-Up System.

## COMPACT CLAMP



### MC5

A clamp for connecting parts with diameters of between 9mm to 12mm together. By combining a boom arm (MCB30EN, MCB45EN) and an L-rod (LLT, LCB, LCYE), this clamp can be used to attach a variety of parts onto a simple boom arm.

## COMPACT CLAMP



### MC7

Same function as the MC5, but with even greater flexibility. The ratchet holder section can hold any diameter tube from 12mm to 25.4mm.

## HOOP GRIP



### MC8

The Hoop Grip is a simple tool that allows you to add cymbals or other accessories to your drum kit to expand your setup and customize your sound.

-available on Steel Hoops and Die-Cast Hoops.  
\*NOT available on Wood Hoops.

## Z-ROD FOR COWBELL



### ZCB

Z-rod for mounting cowbell or other percussion instruments and accessories (9mm diameter)

## Z-ROD FOR SPLASH CYMBAL -LONG



### ZCYEL

Z-rod for mounting lightweight cymbals (10.5mm diameter)

Details:  
- Quick-set cymbal mate

## Z-ROD FOR SPLASH CYMBAL -SHORT



### ZCYE

Z-rod for mounting lightweight cymbals (10.5mm diameter)

Details:  
- Quick-set cymbal mate

## ACCESSORY MOUNT ARM



### HCA20

Accessory mount arm for mounting cymbals or accessories for snare drum effects (10.5mm diameter base section)

## HOOP GRIP & ACCESSORY MOUNT ARM



### MC8HCA20

Hoop Grip (MC8) & Accessory Mount Arm (HCA20) bundle package

## HOOP GRIP & Z-ROD FOR COWBELL



### MC8ZCB

Hoop Grip (MC8) & Z-Rod for Cowbell (ZCB) bundle package

## HOOP GRIP & Z-ROD FOR SPLASH CYMBAL



### MC8ZCYE

Hoop Grip (MC8) & Z-Rod for Splash Cymbal (ZCYE) bundle package

## HOOP GRIP & Z-ROD FOR SPLASH CYMBAL (LONG)



### MC8ZCYEL

Hoop Grip (MC8) & Long Z-Rod for Splash Cymbal (ZCYEL) bundle package

## CLOSED HI-HAT ATTACHMENT



### MXA43

This closed hi-hat attachment utilizes a specially designed screw clutch, allowing for quick, easy, and precise adjustments. The space between the hi-hat cymbals can be adjusted by rotating the screw clutch clockwise or counterclockwise.

## CLOSED HI-HAT ATTACHMENT



### MXA53

Simply designed closed hi-hat attachment that allows for two different settings by turning a lever. Attachable to stands from 15.9mm to 28.6mm in diameter. Great for double bass or double pedal players.

## CLOSED HI-HAT ATTACHMENT



### MXA73N

The tension adjustment knob makes it possible to finely adjust the degree of opening of the hi-hat cymbals. In addition, the angle of the bottom cymbal is also adjustable.

- Quick-set hi-hat clutch
- Quick-set tilter

## L-ROD FOR TOM TOM



### LLT

L-rod for mounting toms (10.5mm diameter).

## L-ROD FOR COWBELL



### LCB

L-rod for mounting different hand percussion instruments and accessories. The 9mm diameter rod fits most popular percussion instruments designed for attachment to a 3/8" rod.

## L-ROD FOR CYMBAL



### LCYE

L-rod for mounting lightweight cymbals.

- Details:
- Quick-set cymbal mate

## L-ROD FOR HI-HAT CYMBAL



### LHH

L-Rod for Hi-hat cymbals.

- Details:
- Screw-Type Hi-hat clutch

## HAT STACK



### CSH5

- Easily attach a small cymbal to hi-hat rod measuring up to 7mm in diameter
- Compact size and lightweight for easy transport and storage
- 25mm (1") diameter x 40mm (1.5") height
- Ability to adjust cymbal sustain

## CYMBAL STACKER



### CSA15

The CSA15 is a straight-forward cymbal stacker useful for adding small cymbals to your setup using the M8 threaded cymbal rod.

## CYMBAL STACKER



### CSA25

The CSA25 allows positioning of a small cymbal on the M8 threaded cymbal rod, as well as independent angle adjustment.

## RATCHET ARM



### MTA30

The MTA30 ratchet arm features a 19.1mm pipe.

- Details:
- 300mm (11 3/4") length

## RATCHET ARM



### MTA45

The MTA45 ratchet arm features a 19.1mm pipe.

- Details:
- 450mm (17 3/4") length

## BOOM ARM



### MCB30EN

MCB30EN can be used in combination with a ratchet arm or the MC66 universal clamp is available.

- Details:
- 300mm (11 3/4") length
  - Quick-set tilter
  - Quick-set cymbal mate

## BOOM ARM



### MCB45EN

MCB45EN can be used in combination with a ratchet arm or the MC66 universal clamp is available.

- Details:
- 450mm (17 3/4") length
  - Quick-set tilter
  - Quick-set cymbal mate

## CYMBAL HOLDER



### CACLJ

Bass Drum Mounted Cymbal Holder features telescoping arm & fine gear tilter, which allow you to adjust the angle and height of the cymbal as you like in smaller spaces.

## CYMBAL HOLDER



### CA30EN

- Details:
- 300mm (11 3/4") length
  - Quick-set tilter
  - Quick-set cymbal mate

## CYMBAL HOLDER



### CA45EN

- Details:
- 450mm (17 3/4") length
  - Quick-set tilter
  - Quick-set cymbal mate

## CYMBAL ATTACHMENT



### CCA30

The assortment of boom cymbal holder and MC61 multi-clamp. By connecting to stands from 15.9mm to 28.6mm in diameter, you can add any cymbal easily.

## CYMBAL ATTACHMENT



### MCA53

The MCA53 is a simplified attachment based on the functionality of the MCA63EN. Add cymbals by securing this attachment to stands from 15.9mm to 28.6mm in diameter.

## CYMBAL ATTACHMENT



### MCA63EN

Combines the MC66 universal clamp and the MCB30EN boom arm. Works perfectly for adding cymbals and accessories to stands with pipes from 15.9mm to 28.6mm in diameter.

Details:  
- Quick-set tilter  
- Quick-set cymbal mate

## CYMBAL ATTACHMENT



### CYA5E

Combines the MC5 compact clamp with the LCYE L-rod for mounting one cymbal to one boom arm. Can be clamped to rods from 9mm to 12mm in diameter or to the L-rod of a tom holder.

Details: Quick-set cymbal mate

## TOM ATTACHMENT



### MC69

Clamping this attachment on a 15.9mm to 28.6mm diameter pipe allows for direct set-up of toms. Even with a compact construction, the inclusion of the Omni-ball feature at the angle adjustment point lets you adjust toms to any angle.

## TOM ADAPTER



### MTH900AS

This adapter allows you to add single toms to stands using the flexibility and speed of TAMA's Omni-Ball/L-rod combination.



PHILO TSOUNGUI | TAREK & MEGALOH & MINE

## COWBELL ATTACHMENT



### CBH20

This simple attachment allows cowbells to be mounted on the bass drum. The length and angle of the L-rod can be easily changed for optimum positioning.

## COWBELL ATTACHMENT



### CBA5

Compact attachment for mounting hand percussion such as cowbells or tambourines. Combines the MC5 compact clamp and the LCB L-rod to provide set-up flexibility. The 3/8" L-rod fits most popular percussion instruments and accessories.

## COWBELL ATTACHMENT



### CBA5E

Combines the universal clamp with the LCB L-rod to mount most popular percussion instruments and accessories. Can be attached to pipes ranging from 15.9 mm to 28.6 mm in diameter.

## HI-HAT ATTACHMENT



### MHA623

Connects the hi-hat to the hoop of a double bass drum so the hi-hat legs can be closed. An improved design featuring the Para-Clamp mechanism from the Iron Cobra pedal makes attachment even easier and more secure.

**NEW**

## HOOP GRIP FOR BASS DRUM



### MC9

The MC9 Hoop Grip for bass drum is a simple clamp. However, when combined with an L-Rod or Z-Rod, you can set splash cymbal or various percussion items on the bass drum.

## COWBELL ATTACHMENT



### CBH50

The position and angle of the cowbell are adjustable to your preference. The bass drum clamp is now equipped with rubber hoop protectors in order to prevent the hoop from becoming damaged.

## HI-HAT ATTACHMENT



### MHA823

This hi-hat attachment allows for better positioning of a hi-hat stand while using a double bass drum set-up. By connecting the MHA823 to the bass drum hoop, the hi-hat stand can be held upright without opening the hi-hat stand's legs. By utilizing TAMA Omni-Ball system, the clamp is now infinitely adjustable to any angle and enables even greater set-up flexibility. As well, rubber cushions are equipped to protect bass drum hoop from becoming damaged. The clamp is attachable to any hi-hat stand with a pipe diameter of 15.9 - 28.6mm by using the FastClamp Easy Set-Up System.

# MICROPHONE STANDS

Just as many years ago, TAMA single-handedly altered the essence of the modern drum set through its re-invention of drum hardware—TAMA now turns that same degree of engineering dedication to yet another unevolved category of music gear: the microphone stand.

## IRON WORKS STUDIO TELESCOPING BOOM STAND



### MS736BK

- Vice-Grip Boom Tilter
- Iron-Core Legs with Vibration-Isolating Rubber Feet
- Iron-Core Telescoping Boom Arm
- Silent T-Handle
- Detachable Boom Arm
- Height : 975-1650mm (38 3/8"-64 15/16")
- Boom arm : 505-850mm (19 7/8"-33 7/16")
- Weight : 5.4kg (11.9lbs)
- Black Finish

## IRON WORKS STUDIO LOW PROFILE TELESCOPING BOOM STAND



### MS736LBK

- Vice-Grip Boom Tilter
- Iron-Core Legs with Vibration-Isolating Rubber Feet
- Iron-Core Telescoping Boom Arm
- Silent T-Handle
- Detachable Boom Arm
- Height : 440mm - 605mm (17 5/16"– 23 13/16")
- Boom arm : 505mm – 850mm (19 7/8"– 33 7/16")
- Weight : 4.7kg (10.4lbs)
- Black Finish

## IRON WORKS STUDIO ROUND BASE EXTRA LOW PROFILE TELESCOPING BOOM STAND



### MS736RELBK

- Vice-Grip Boom Tilter
- Iron-Core Telescoping Boom Arm
- Silent T-Handle
- Detachable Boom Arm
- Heavy Round Cast Base
- Height : 280mm (11 1/32")
- Boom arm : 505mm – 850mm (19 7/8"– 33 7/16")
- Weight : 7.7kg (17.0lbs)
- Black Finish

## IRON WORKS TOUR TELESCOPING BOOM STAND



### MS436BK

- Cast Grip Boom Tilter
- Die-Cast Locking Thumb Nut
- Sure-Cast Adjustment Collar
- Iron-Core Telescoping Boom Arm
- Detachable Boom Arm
- Height : 985mm – 1660mm (38 3/4"– 65 3/8")
- Boom arm : 845mm (33 1/4")
- Weight : 3.9kg (8.6lbs)
- Black Finish

## IRON WORKS TOUR LOW PROFILE TELESCOPING BOOM STAND



### MS436LBK

- Cast Grip Boom Tilter
- Die-Cast Locking Thumb Nut
- Sure-Cast Adjustment Collar
- Iron-Core Telescoping Boom Arm
- Detachable Boom Arm
- Height : 440mm – 605mm (17 5/16"– 23 13/16")
- Boom arm : 505mm – 845mm (19 7/8"– 33 1/4")
- Weight : 3.1kg (6.9lbs)
- Black Finish

## BOOM STAND



### MS205

- Cast Grip Boom Tilter
- Height : 960mm – 1600mm (37 13/16"– 63")
- Boom arm : 830mm (32 11/16")
- Weight : 3.2kg (7.1 lbs)
- Chrome Finish

## BOOM STAND



### MS205BK

- Cast Grip Boom Tilter
- Height : 960mm – 1600mm (37 13/16"– 63")
- Boom arm : 830mm (32 11/16")
- Weight : 3.2kg (7.1 lbs)
- Black Finish

## LOW PROFILE BOOM STAND



### MS205ST

- Cast Grip Boom Tilter
- Height : 430mm – 560mm (17 1/8"– 22 1/16")
- Boom arm : 510mm (20 1/16")
- Weight : 2.3kg (5.1 lbs)
- Chrome Finish

**NEW****IRON WORKS STUDIO ROUND BASE TELESCOPING BOOM STAND****MS736RBK**

- Vice-Grip Boom Tilter
- Sure-Cast Adjustment Collar
- Die-Cast Locking Thumb Nut
- Round Cast Base
- Silent T-Handle
- Latch-Lok Sleeve Insert
- Iron-Core Telescoping Boom Arm
- Height : 990-1700mm (38 3/8"-64 15/16")
- Weight : 8.2kg
- Black Finish

**NEW****IRON WORKS TOUR TABLE TOPSTAND****MS30BK**

- Lighter Smaller Zinc Die-Cast Round Base
- 2 stage Aluminum Pipe Construction
- Height : 220mm - 370mm (8 5/8"-14 9/16")
- Weight : 1.1kg
- Black Finish

**LOW PROFILE BOOM STAND****MS205STBK**

- Cast Grip Boom Tilter
- Height : 430mm – 560mm (17 1/8" – 22 1/16")
- Boom arm : 510mm (20 1/16")
- Weight : 2.3kg (5.1 lbs)
- Black Finish

**STRAIGHT STAND****MS200BK**

- Height : 910 - 1550mm (36" - 61")
- Weight : 2.4kg (5.4lbs)
- Black Finish

**STRAIGHT STAND WITH ROUND BASE****MS200DBK**

- Cast Round Base with T-Bolt Pipe Fixing Device
- Height : 895 - 1510mm (35 1/4" - 59 7/16")
- Weight : 3.8kg (8.6lbs)
- Black Finish



ANSGAR FREYBERG | THE BOSS HOSS

**BOOM ARM****MS736BB**

- Vice-Grip Boom Tilter with Iron-Core Telescoping Boom Arm

**BOOM ARM****MS436BB**

- Cast-Grip Boom Tilter with Iron-Core Telescoping Boom Arm

**CORD CLIP****CC5**

- For 15.9 mm (5/8") diameter tube.

**CORD CLIP****CC7**

- For 22.2 mm (7/8") diameter tube.

**DIE-CAST LOCKING THUMB NUT****DTLN3**

- For 3/8" connector
- Not only does the thumb nut's larger, sure-grip design allow greater leverage for faster, easier set-up and breakdown, its high quality zinc threads and walls are built to handle pressure for years to come.

**RUBBER FOOT****756-RF**

- TAMA's extra thick rubber foot covers "float" the stand, isolating the microphone from floor vibrations. (for 19.1mm diameter leg)



# TAMA PERCUSSION

For more than 40 years, TAMA has been inspiring drummers around the world with its unique range of original percussion instruments. Combining the influences of global musical cultures with modern technology, TAMA has given drummers and percussionists of every genre a new lease on creativity with the unique voices these instruments provide.

## GONG BASS DRUM

**NEW**



### MG20R

MADE IN JAPAN

20"x14" Starclassic Maple Gong Bass Drum

An early TAMA original, the Gong Bass Drum uses a 22" head mounted Tympani style on a 20" shell with no bottom head.

\*Gong Bass Drums is available in Piano Black (PBK) finish only.

## METALWORKS "EFFECT" STEEL MINI-TYMPIS



### MT68STBK

6"x4" + 8"x4"

### MT810STBK

8"x4" + 10"x4"

### MT1012STBK

10"x4" + 12"x4"

Steel Mini-Tympis come with an L-rod (LLT) and multi-clamp (MC66)

## JINGLE RING



### TJR7

The Jingle Ring is a slim tambourine that can be mounted on a hi-hat stand or as a separate item. It features 9 pairs of nickel "jingles" that produce a bright, clear, tambourine sound.

## OCTOBAN SET



### 7850N2H

2pc High-pitch set w/ HOW29WN stand

HOW29WN available separately

## OCTOBAN SET



### 7850N2L

2pc Low-pitch set w/ HOW29WN stand

HOW29WN available separately

## SONIC COWBELL



### TSC4

4" Cowbell

## OCTOBAN SET



### 7850N4H

4pc High-pitch set w/ HOW49WN stand

## OCTOBAN SET



### 7850N4L

4pc Low-pitch set w/ HOW49WN stand



SIMON PHILLIPS

## OCTOBAN SINGLE



### OCT280N

280mm (11") depth

### OCT343N

343mm (13 1/2") depth

### OCT301N

301mm (11 3/4") depth

### OCT390N

390mm (15 1/2") depth

### OCT443N

443mm (17 1/2") depth

### OCT472N

472mm (18 1/2") depth

### OCT536N

536mm (21") depth

### OCT600N

600mm (23 1/2") depth

## OCTOBAN HOLDER FOR DRUM RACK



### OA29

for 2pcs octobans



### OA49

for 4pcs octobans

# PRACTICE TOOLS

Our unique practice tools make your percussive education more enjoyable and productive.

## PRACTICE PAD



### TSP9

This practice pad accurately imitates the natural feel & rebound of an acoustic snare drum. The wooden base and 6mm thick rubber playing surface offer excellent durability. This combination provides easy control and is ideal for hours long practice sessions. The non-slip base allows the practice pad to rest on a tabletop or snare drum without damaging the surface beneath.

- Unique Playing Surface
- A Natural Feel with the Perfect Bounce
- Portable Compact Size - 9"
- Non-Skid Soft Foam Base

## PRACTICE PAD



### TMP8S

This snare pad is an actual 8" x 4" inch drum with a mesh head. It has a half cut snare wire facing the backside of the mesh head from inside the drum.

## PRACTICE PAD



### TSP6

The special urethane foam on this pad provides a nice bouncy feel for more enjoyable and more productive practice. The six-inch diameter size also makes it easily portable.

## PRACTICE PAD STAND



### HS40TPN

The HS40TPN practice pad stand can hold pads between 6 and 10 inches in diameter. The EP222 Extension Pipe sold separately.

- Single Braced Legs
- Height Adjustment Range w/o extension pipe: 580mm - 710mm (22 13/16" - 27 15/16") w/ extension pipe (EP222): 790mm - 1,065mm (31 1/8" - 41 15/16")

## SOFT SOUND BEATER



### BSQ10S

Soft Sound Beater provides a significant decrease in volume, but allows you to use your regular bass drum pedal and bass drum head with a natural and accurate feel.

### BSQ5S

Half size version for twin pedal users

## SILENT TIPS



### TCP20

TAMA TCP20 is a pair of silicone rubber tips that fit over most drum stick models. These tips make it easy and convenient to practice silently, anytime, anywhere.

## EXTENSION PIPE FOR PRACTICE PAD STAND



### EP222

The height of the HS40TPN can be easily extended by attaching the EP222 extension pipe between the upper and lower section of unit. No tools are required to install this product.

## SOFT SOUND PACKAGE

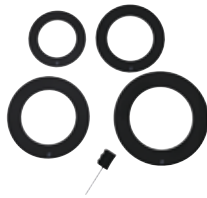

The Soft Sound package reduces the volume of an acoustic drum kit while retaining the natural tone of the shell. It is designed to maintain the feel of playing an acoustic drum kit; a very important feature when playing in low volume situations.

### SSRP52K

22"BD 5pc kit configuration  
-10", 12", 14", and 16" SSR  
-Half Soft Sound Beater (BSQ5S)

### SSRP50

20"BD 5pc kit configuration  
-10", 12", and 2pcs of 14" SSR  
-Half Soft Sound Beater (BSQ5S)

### SSRP48

18"BD 4pc kit configuration  
-10", 13", and 14" SSR  
-Half Soft Sound Beater (BSQ5S)

## SOFT SOUND RING

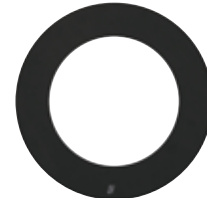

### SSR8

The TAMA Soft Sound Ring is made of 6mm thick foam rubber. This drum accessory reduces the volume of an acoustic drum kit while retaining the natural tone of the shell.

- SSR8 (8")
- SSR10 (10")
- SSR12 (12")
- SSR13 (13")
- SSR14 (14")
- SSR16 (16")

## CYMBAL MUTE



### CM14HH

for 14" hi-hat cymbal

### CM1416

for 14" or 16" cymbal



### CM1820

for 18" or 20" cymbal



## MESH HEAD



### MH8T

- MH8T (8")
- MH10T (10")
- MH12T (12")
- MH13T (13")
- MH14T (14")
- MH16T (16")
- MH18B (18")
- MH22B (22")

## SILENT PRACTICE SET



### SPP518CN

Mesh head for 18" bass drum  
Mesh head for 10" tom tom  
Mesh head for 12" tom tom  
Mesh head for 14" floor tom & snare drum (x2)  
Cymbal mute for 14" hi-hat cymbal  
Cymbal mute for 14" or 16" cymbal  
Cymbal mute for 18" or 20" cymbal

### SPP522C

Mesh head for 22" bass drum  
Mesh head for 12" tom tom  
Mesh head for 13" tom tom  
Mesh head for 16" floor tom  
Mesh head for 14" snare drum  
Cymbal mute for 14" hi-hat cymbal  
Cymbal mute for 14" or 16" cymbal  
Cymbal mute for 18" or 20" cymbal

### SPP522KC

Mesh head for 22" bass drum  
Mesh head for 10" tom tom  
Mesh head for 12" tom tom  
Mesh head for 16" floor tom  
Mesh head for 14" snare drum  
Cymbal mute for 14" hi-hat cymbal  
Cymbal mute for 14" or 16" cymbal  
Cymbal mute for 18" or 20" cymbal

# BAGS

TAMA's heavy duty bags protect your drums from damage during transportation.

## POWERPAD BAG -Tom Tom-



### PBT8

PBT8 (8"x7" Tom Tom)  
PBT10 (10"x8" Tom Tom)  
PBT12 (12"x9" Tom Tom)  
PBT13 (13"x10" Tom Tom)  
PBT14 (14"x11" Tom Tom)

## POWERPAD BAG -Floor Tom-



### PBF14

PBF14 (14"x14" Floor Tom)  
PBF16 (16"x16" Floor Tom)

## POWERPAD BAG -Bass Drum-



### PBB18

PBB18 (16"x18" Bass Drum or Floor Tom)  
PBB20 (20"x18" Bass Drum)  
PBB22 (22"x18" Bass Drum)  
PBB22X (22"x20" Bass Drum)  
PBB24 (24"x18" Bass Drum)

## POWERPAD BAG -Snare Drum-



### PBS1455

PBS1455 (14"x5.5" Snare Drum)  
PBS1465 (14"x6.5" Snare Drum)  
PBS1480 (14"x8" Snare Drum)

## POWERPAD BAG -Hardware-



### PBH02L

880 (L) x 150 (W) x 200 (H) mm  
(34 5/8" x 5 7/8" x 7 7/8")

-Suitable size for storing about 5 stand

## POWERPAD BAG -Hardware-



### PBH05

850 (L) x 320 (W) x 220 (H) mm  
(33 1/2" x 12 5/8" x 8 5/8")

-Suitable size for storing about 10 stands  
-Equipped with durable wheels



BASTIAN EMIG | VAN CANTO

## POWERPAD BAG -Cymbal-



### PBC22

The POWERPAD® Series Cymbal Bag is a heavy duty bag designed to carry cymbals up to 22" in diameter. The main compartment contains (3) 22" dividers and the front side pocket contains (3) 15" dividers.

## POWERPAD BAG -Twin Pedal-



### PBP200

The PBP200 can accommodate both single and double pedals.

450 (L) x 300 (W) x 200 (H) mm

## POWERPAD BAG -Single Pedal-



### PBP100

The POWERPAD® Series bag for single pedal.

220 (D) x 190 (W) x 400 (H) mm

## POWERPAD BAG -Drum Throne-



### PBTH15

-Carries any TAMA drum throne  
-Carries 14" snare drum and snare drum stand  
-Shoulder strap and handle for easy transportation

## POWERPAD BAG -Stick & Mallet-



### PBS50

Stores about 24 pairs of sticks & mallets

-Large front pocket for sheet music  
-Built-in hooks easily attach to floor tom  
-Padded Shoulder strap  
-Convenient inner pockets  
-Height: 500mm  
-Open Width: 580mm

## POWERPAD BAG -Stick-



### PBS24

Stores about 12 pairs of sticks & mallets

## POWERPAD DESIGNER BAG -Snare Drum-



**NEW**

### TSDB1465

- 14"x6.5" Snare Drum
- Convertible Backpack Straps
- 20mm thick semi-hard cushion
- Backpack Straps and ergonomic rubber handle

**NEW**

- Moss Green (MG)
- Black (BK)
- Navy Blue (NB)
- Wine Red (WR)
- Beige (BE)



## POWERPAD BAG -Hardware-

### THB02L

- 880 (L) x 150 (W) x 200 (H) mm
- (34 5/8" x 5 7/8" x 7 7/8")
- Suitable size for storing about 4 stands

**NEW**

- Black (BK)
- Moss Green (MG)
- Navy Blue (NB)
- Wine Red (WR)
- Beige (BE)



**NEW**



## POWERPAD DESIGNER BAG -Drum Set-

**NEW**

### TDSS52K

- Black
- 22"x18" Bass Drum
- 10"x8" Tom Tom
- 12"x9" Tom Tom
- 16"x16" Floor Tom
- 14"x6.5" Snare Drum

- 10mm thick inner cushions
- Ergonomic rubber handle
- A comfortable padded shoulder strap (for the snare drum bag)

- Moss Green (MG)
- Navy Blue (NB)



- Wine Red (WR)
- Black (BK)



## POWERPAD DESIGNER BAG -8" Tom Tom-

**NEW**

### TSBT8

- 8"x7" Tom Tom
- 10mm thick inner cushions
- Ergonomic rubber handle

- Black (BK)
- Moss Green (MG)
- Navy Blue (NB)
- Wine Red (WR)
- Beige (BE)



## POWERPAD DESIGNER BAG -14" Floor Tom-

**NEW**

### TSBF14

- 14"x14" Tom Tom
- 10mm thick inner cushions
- Ergonomic rubber handle

- Black (BK)
- Moss Green (MG)
- Navy Blue (NB)
- Wine Red (WR)
- Beige (BE)



## POWERPAD DESIGNER BAG -Cymbal-

### TCB22

- Moss Green
- up to 22" Cymbal + 15" Cymbal
- (front side pocket)

- 20mm thick semi-hard cushion
- Padded shoulder Straps and handle
- 22" compartment dividers (3pcs)
- and 15" compartment dividers (3pcs) included

- Beige (BE)
- Navy Blue (NB)



**NEW**

## POWERPAD DESIGNER BAG -Cajon-

### TCB01

- 330 (L) x 310 (W) x 520 (H) mm
- (13" x 12 1/4" x 20 1/2")
- Backpack straps

- Black (BK)
- Moss Green (MG)
- Navy Blue (NB)
- Wine Red (WR)
- Beige (BE)



## POWERPAD DESIGNER BAG -Twin Pedal-

### TPB200

- 450 (L) x 200 (W) x 300 (H) mm
- (17 3/4" x 7 7/8" x 11 3/4")
- Accommodate both single and double pedals
- Removable storage case for using as single pedal case

- Black (BK)
- Moss Green (MG)
- Navy Blue (NB)
- Wine Red (WR)
- Beige (BE)



## POWERPAD DESIGNER BAG -Stick-

### TSB24

- Main pockets for 12 pairs of sticks, and side pockets for accessories
- Built-in hooks easily attach to floor tom
- Shoulder strap for portability
- Convenient inner pockets
- Size: 460mm x 180mm
- Side Pocket: 260mm x 160mm

- Beige (BE)
- Navy Blue (NB)



- Moss Green (MG)
- Black (BK)



**NEW**

### TSB12

- Stores about 6 pairs of sticks
- Top of the bag open to take out stick easily
- Elastic band easily attach to floor tom
- Convenient inner pockets

- Beige (BE)
- Moss Green (MG)
- Black Denim (DBK)
- Black (BK)



**NEW**

## STANDARD SERIES DRUM BAG SET

### FEATURES

- 600 denier high density water resister surface
- Water resistant nylon with 10mm thick cushion
- Ergonomic rubber handles



### DSS36LJ NEW

16"x15" BD  
10"x7" TT  
12"x6" FT  
(for Club-JAM Suitcase kit)

### DSS52K

22"x18"BD  
10"x8"TT  
12"x9"TT  
16"x16"FT  
14"x6.5"SD

### DSS50S

20"x18"BD  
10"x8"TT  
12"x9"TT  
14"x14"FT  
14"x6.5" SD

### DSS62S

22"x18"BD  
10"x8"TT  
12"x9"TT  
14"x14"FT  
16"x16"FT  
14"x6.5"SD

### DSS72S

22"x18" BD  
8"x7" TT  
10"x8" TT  
12"x9" TT  
14"x14" FT  
16"x16" FT  
14"x6.5" SD

### DSS62H

22"x18"BD  
10"x6.5"TT & 12"x7"TT (1bag)  
14"x14" FT  
16"x16"FT  
14"x6.5"SD

### DSS48LJ

(for Club-JAM kit)  
18"x12" BD  
10"x8" TT  
14"x7" FT & 13"x5" SD (1bag)

### DSS44LJ

(for Club-JAM Flyer kit)  
14"x10" BD  
10"x9" FT & 8"x6" TT (1bag)  
10"x5" SD bag

### DSS28LJ

(for Club-JAM MINI kit)  
18"x12" BD  
12"x5" SD

### DSS48S

18"x14" BD  
12"x9" TT  
14"x14" FT  
14"x6.5" SD

NEW



## STANDARD SERIES SNARE BAG



### SBS14

14"x6.5" Snare Drum

- 600 denier high density water resister surface
- Water resistant nylon with 10mm thick cushion
- Ergonomic rubber handles
- Carrying strap with shoulder pads

## STANDARD SERIES HARDWARE BAG



### SBH01

(for Compact / Lightweight Hardware)  
670 (L) x 180 (W) x 190 (H) mm

- 600 denier high density water resister surface
- Water resistant nylon with 10mm thick cushion
- Carrying strap with shoulder pads

## STANDARD SERIES MICROPHONE STAND BAG



### SBM01

Stores up to 6 pcs of Microphone Stands or  
2pcs of Speaker Stands  
1200 (L) x 220 (W) x 200 (H) mm

- 600 denier high density water resister surface
- Water resistant nylon with 10mm thick cushion
- Carrying strap with shoulder pad

## STANDARD SERIES CAJON BAG



### SBC01

Size: 520 (L) x 310 (W) x 330 (H) mm  
Side Pocket: 520 (L) x 50 (W) x 330 (H) mm

- Designed for smooth extraction and insertion of Cajon
- 600 denier high density water resister surface
- Water resistant nylon with 10mm thick cushion

# ACCESSORIES

We offer many unique accessories to enhance your playing, set up, and tone of the drums.

## RHYTHM WATCH



### RW200

Tempo Range: 30-250 BPM  
Tempo, Beat & Sound Memory: 30 Songs  
Beats: 0-9  
Display: LCD with BACK LIGHT  
Size: 127 x 35 x 150mm (5" x 1.4" x 6")  
Weight: 285g including battery  
Power Supply: 9V Battery (S-006P) or DC9V 200mA adapter

## RHYTHM WATCH MINI



### RW30

Tempo Range: 30-250 BPM  
Beats: 0-9  
Display: LCD display with BACK LIGHT  
Size: 61 x 25 x 118mm (2 1/2" x 1" x 4 5/8")  
Weight: 90g including battery  
Power Supply: 2 x AAA Batteries (3V)

## RHYTHM WATCH HOLDER



### RWH10

Holder for RW200

## TENSION WATCH



### TW200

The TW200 TAMA Tension Watch is very compact and is equipped with an easy-to-read dial. It comes with a detachable nylon bumper to ensure consistent measuring distance from the hoop, resulting in an evenly tensioned drum for the best sound.

## TENSION WATCH



### TW100

The TW100 measures actual head tension and features an easy-to-read meter, so you can record the numbers and duplicate your best tuning time after time. You can also use the sample tunings suggested in the directions.

## WOOD HOOP PROTECTOR



### WHP2

(2pcs / set)  
Special adhesive pieces protect your wood hoop from being scratched by preventing the bass drum pedal from twisting or slipping.

## DRUMMER'S GLOVE



### TDG10BKL

Drummer's Glove with featuring extra soft and durable synthetic leather which prevents any slipping while playing even with wet condition caused by sweating.

TDG10BKM (Medium)  
TDG10BKL (Large)  
TDG10BKLX (Extra Large)

## DRUMMER'S GLOVE



### TDG10WHL

Drummer's Glove with featuring extra soft and durable synthetic leather which prevents any slipping while playing even with wet condition caused by sweating.

White  
TDG10WHM (Medium)  
TDG10WHL (Large)

## MULTI TOOL



### TMT9

Quick access multi tool for drums  
-Hex Wrench 5.0mm/4.0mm/3.0mm/2.5mm/2.0mm, Keychain Link, Hex Nut Driver, Phillips Screwdriver, Drum Keys (x2)

## TENSION LOCK



### TTL10

(10pcs/set)  
The Tension Lock prevents tension bolts from loosening while playing by simply set it on the tension bolt head. You can tune the drum without having to detach the Tension Lock, thanks to an elastic O-ring around its hole.

## DRUM RUG -TAMA Logo Pattern / Small-



### TDRS-TL

1,680mm x 1,330mm  
(66 1/8" x 52 3/8")  
-Non-slip design helps keep drums & hardware in place  
-Fits to accommodate compact drum set  
-Hook and loop fasteners for easy transport

NEW

## DRUM RUG -TAMA Logo Pattern-



### TDR-TL

1800mm x 2000mm  
(70 7/8" x 78 3/4")  
-Non-slip design helps keep drums & hardware in place  
-Extra-large size accommodates most drum setups  
-Hook and loop fasteners for easy transport

## DRUM RUG -Oriental Pattern-



### TDR-OR

1800mm x 2000mm  
(70 7/8" x 78 3/4")  
-Non-slip design helps keep drums & hardware in place  
-Extra-large size accommodates most drum setups  
-Hook and loop fasteners for easy transport

## DRUM RUG -Southwestern Pattern-



### TDR-SW

1800mm x 2000mm  
(70 7/8" x 78 3/4")  
-Non-slip design helps keep drums & hardware in place  
-Extra-large size accommodates most drum setups  
-Hook and loop fasteners for easy transport

## DRUM RUG -Paisley Pattern-



### TDR-PA

1800mm x 2000mm  
(70 7/8" x 78 3/4")  
-Non-slip design helps keep drums & hardware in place  
-Extra-large size accommodates most drum setups  
-Hook and loop fasteners for easy transport

## BASS DRUM RESO HEADS



### REMO FIBERSKYN POWERSTROKE 3 DIPLOMAT

(TAMA Logo)  
RF18BMST (18")  
RF20BMST (20")  
RF22BMST (22")  
RF24BMST (24")  
RF26BMST (26")

### WHITE COATED

(TAMA & Starclassic Logo)  
CT18BMOT (18")  
CT20BMOT (20")  
CT22BMOT (22")  
CT24BMOT (24")  
CT26BMOT (26")

### FIBER LAMINATED

(TAMA & Starclassic Logo)  
FB18BMFS (18")  
FB20BMFS (20")  
FB22BMFS (22")  
FB24BMFS (24")

### SMOOTH WHITE

(TAMA & Starclassic Logo)  
SW20BMTT (20")  
SW22BMTT (22")  
SW24BMTT (24")

### WHITE COATED

(TAMA Logo)  
CT18BMSV (18")  
CT20BMSV (20")  
CT22BMSV (22")  
CT24BMSV (24")

### BLACK

(TAMA & Starclassic Logo)  
BK18BMTT (18")  
BK20BMTT (20")  
BK22BMTT (22")  
BK24BMTT (24")  
BK26BMTT (26")

### FIBER LAMINATED BLACK

(TAMA Logo for Superstar Hyper-Drive)  
BK20BMFH (20")  
BK22BMFH (22")  
BK24BMFH (24")

### BLACK

(TAMA Logo)  
BK20BMWS (20")  
BK22BMWS (22")  
BK24BMWS (24")

## DRUM KEYS



**TDK10**  
Chrome



**TDK10BN**  
Black Nickel



**6560R**



**DH7**

## SNARE HOOPS



### DIE-CAST

TAMA's die-cast hoops deliver an incredibly sharp, solid rim shot that cannot be found in any other hoop.  
MDH14-8 (14" 8 hole batter side)  
MDH14S-8 (14" 8 hole snare side)  
MDH14-10 (14" 10 hole batter side)  
MDH14S-10 (14" 10 hole snare side)



### 2.3 MM BRASS MIGHTY

Brass Mighty Hoop provides a warm and open sound with mild attack and long sustain.

MFB14-10N (14" 10 hole batter side)  
MFB14S-10N (14" 10 hole snare side)



### 2.3 MM STEEL MIGHTY

Steel Mighty Hoop provides a bright and open sound.

MFM14-8 (14" 8 hole batter side)  
MFM14S-8 (14" 8 hole snare side)  
MFM14-10 (14" 10 hole batter side)  
MFM14S-10 (14" 10 hole snare side)

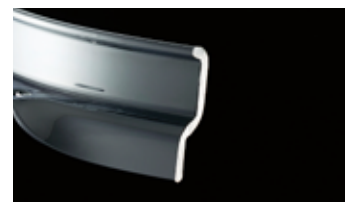

### 3.0MM ULTIMATE STEEL MIGHTY

3.0mm thick Ultimate Steel Mighty Hoop provides extra power and volume.

MUS1410 (14" 10 hole batter side)  
MUS14S10 (14" 10 hole snare side)



### 2.3MM SOUND ARC

Steel Sound Arc Hoop enhances the natural tone of the snare drum and offers sensitivity, precise tuning, and control.

MSH1410 (14" 10 hole batter side)  
MSH14S10 (14" 10 hole snare side)



### MAPLE WOOD HOOPS

Wood Hoop provides a warm, woody sound with soft attack. Can be mounted on a standard 14" snare drum stand.

WMH1408B (14" 8 hole batter side)  
WMH1408S (14" 8 hole snare side)  
WMH1410B (14" 10 hole batter side)  
WMH1410S (14" 10 hole snare side)



### 2.3MM BRASS SOUND ARC

Brass Sound Arc Hoop provides an open sound with rich harmonic overtones, made of brass with an inward curved shape.

MSB148D (14" 8 hole batter side)  
MSB14S8D (14" 8 hole snare side)

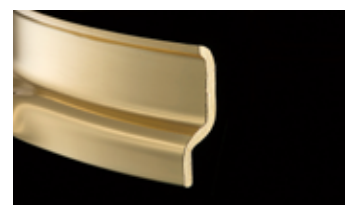

### CUSTOMIZED BRASS MIGHTY

Customized Brass Mighty Hoop provides a sharper and brighter attack with rich harmonic overtones, made of brass with a slightly shaved down edge.

MSP14-8 (14" 8 hole batter side)  
MSP14S-8 (14" 8 hole snare side)

## SNARE WIRES



### SUPER SENSITIVE HI-CARBON

Super Sensitive Hi-Carbon Snare Wire fits more closely to the snare side head, providing greater sensitivity and brighter, crisper sound.

MS20RL13C (13" 20 strands Hi-Carbon Steel)  
MS20RL14C (14" 20 strands Hi-Carbon Steel)



### STAINLESS STEEL STRAIGHT

20 strands steel straight wire for concert. Extra short sustain, dark and crisp.

MS20M14ST (14" 20 strands Steel)



### STARCLASSIC -CARBON STEEL-

20 strands steel straight wire for concert. Extra short sustain, dark and crisp.

MS20M14ST (14" 20 strands Steel)



### STARCLASSIC -BELL BRASS-

The MS20SN14B features bell brass strands for greater sensitivity.

MS20SN14B (14" 20 strands Bell Brass)



### STARCLASSIC -HI-CARBON STEEL-

MS20SN13C (13" 20 strands Hi-Carbon Steel)  
MS20SN14C (14" 20 strands Hi-Carbon Steel)



### REGULAR SNARE WIRES -CARBON STEEL-

MS12R14S (14" 12 strands Carbon Steel)



### REGULAR SNARE WIRES -CARBON STEEL-

MS20R14S 14" 20 strands Carbon Steel



### REGULAR SNARE WIRES -CARBON STEEL-

MS30R14S (14" 30 strands Carbon Steel)



### REGULAR SNARE WIRES -CARBON STEEL-

MS42R14S (14" 42 strands Carbon Steel)



### REGULAR SNARE WIRES -HI-CARBON STEEL-

MS42R14C (14" 42 strands Hi-Carbon Steel)

## SNARE WIRE STRAPS

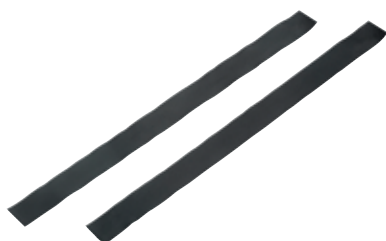

### MST20

(2pcs/set)

These flexible yet durable 15mm wide nylon snare wire straps are featured on most of TAMA snare drums.

## SNARE WIRE STRINGS



### SPC50P4

(2prs/pack)

The amazingly durable and flexible snare wire string is made of Dupont Kevlar® cable wrapped in polyester fiber for an even higher tensile strength than steel wire. (Kevlar® is a registered trademark of Dupont® Corporation.)



## METAL WASHERS



### MW620

(20pcs/set)  
Standard metal tension bolt washers.

## HOLD TIGHT™ WASHERS



### SRW620P

(20pcs/set)  
The rubber rings inside of the cup-shaped stainless steel washers absorb impact vibrations and keep the hoop and tension bolts in constant contact to prevent from loosening of tension.

## PLASTIC WASHERS



### PW620

(20pcs/set)  
2.5mm thick nylon washers decrease noise and make tuning easier and more stable.

## BEATERS



Featuring black felt and a slightly tapered shape, this traditional style beater provides impact to the bass drum head surface evenly to maximize clear, dynamic articulation.

BDY30FB



### POWER-STRIKE COBRA BEATER

CB900PS - Felt



### ACCU-STRIKE COBRA BEATER

CB900AS - Rubber



### COBRA BEATER -FELT-

CB90F - Felt



### COBRA BEATER -RUBBER-

CB90R - Rubber



### COBRA BEATER -WOOD-

CB90W - Wood

### DYNA BEATER



### TRADITIONAL -WOOD-

TTB30W - Wood



### TRADITIONAL -FELT-

TTB30F - Felt



### THE CLASSIC -FELT-

CLB30F - Felt



### DUAL SIDED -FELT-

DS30 - Felt-Plastic



### DUAL SIDED -FELT-

DS30G - Felt-Plastic



### DUAL SIDED -RUBBER-

DS30 - Felt-Plastic

## ACCU-STRIKE COBRA BEATER HEAD



### CB900ASH

Rubber

## COBRA BEATER HEAD -Wood-



### CB90WH

Wood

## COBRA BEATER HEAD -Rubber-



### CB90RH

Rubber

## POWER-STRIKE COBRA BEATER HEAD



### CB900PSH

Felt

## COBRA BEATER HEAD -Felt-



### CB90FH

Felt

## TOE STOPPER



**HP900-81**

## BEATER BALANCER



**BC7**

## TIGHT LOCK



**TLK5**

## SPRING FOR SPEED COBRA



**HP910-7S**

## SPRING -Regular-



**HP900-7R**

## SPRING -Heavy-



**HP900-7H**

## COBRA COIL



**CC900S**

The Cobra Coil is a steel spring which assists in the return of the footboard to its original position. It be adjusted to different positions, forward or backward, on the base plate.

## DRUM HAMMER



**DH7**

## TWIN PEDAL ATTACHMENT

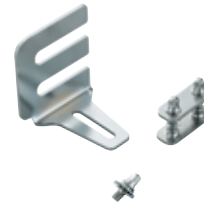

**TPA90**

Specially designed attachment to connect Speed Cobra and Iron Cobra 900 series pedals with Speed Cobra and Iron Cobra 900 series Hi-hat stands.

## DYNA-SYNC PEDAL CASE -SINGLE-



**PCDS1**

PCDS1 (for Dyna-Sync Single Pedal)

## IRON COBRA PEDAL CASE -SINGLE-



**PC900S**

PC900S (for Iron Cobra Single Pedal)

## SPEED COBRA PEDAL CASE -SINGLE-



**PC910S**

PC910S (for Speed Cobra Single Pedal)

## DYNA-SYNC PEDAL CASE -TWIN-



**PCDS1TW**

PCDS1TW (for Dyna-Sync Twin Pedal)

## IRON COBRA PEDAL CASE -TWIN-



**PC900TW**

PC900TW (for Iron Cobra Twin Pedal)

## SPEED COBRA PEDAL CASE -TWIN-



**PC910TW**

PC910TW (for Speed Cobra Twin Pedal)

### 1ST CHAIR ROUND RIDER XL SEAT -Cloth Top-



#### HTS8BC

You can improve your existing throne with the firm support and comfort of 1st Chair seats (fits pipes from 19.1mm to 25.4mm in diameter).

### 1ST CHAIR ROUND RIDER XL SEAT



#### HTS8B

You can improve your existing throne with the firm support and comfort of 1st Chair seats (fits pipes from 19.1mm to 25.4mm in diameter).

### 1ST CHAIR ROUND RIDER XL SEAT -Red-



#### HTS8R

You can improve your existing throne with the firm support and comfort of 1st Chair seats (fits pipes from 19.1mm to 25.4mm in diameter).

### 1ST CHAIR ERGO-RIDER SEAT -Cloth Top-



#### HTS7BC

You can improve your existing throne with the firm support and comfort of 1st Chair seats (fits pipes from 19.1mm to 25.4mm in diameter).

### 1ST CHAIR ERGO-RIDER SEAT



#### HTS7B

You can improve your existing throne with the firm support and comfort of 1st Chair seats (fits pipes from 19.1mm to 25.4mm in diameter).

### 1ST CHAIR GLIDE RIDER SEAT -Cloth Top-



#### HTS5BCN

You can improve your existing throne with the firm support and comfort of 1st Chair seats (fits pipes from 19.1mm to 25.4mm in diameter).

### 1ST CHAIR WIDE RIDER SEAT -Cloth Top-



#### HTS5BC

You can improve your existing throne with the firm support and comfort of 1st Chair seats (fits pipes from 19.1mm to 25.4mm in diameter).

### 1ST CHAIR WIDE RIDER SEAT



#### HTS5B

You can improve your existing throne with the firm support and comfort of 1st Chair seats (fits pipes from 19.1mm to 25.4mm in diameter).

### 1ST CHAIR ROUND RIDER SEAT -Cloth Top-



#### HTS4BC

You can improve your existing throne with the firm support and comfort of 1st Chair seats (fits pipes from 19.1mm to 25.4mm in diameter).

### 1ST CHAIR ROUND RIDER SEAT



#### HTS4B

You can improve your existing throne with the firm support and comfort of 1st Chair seats (fits pipes from 19.1mm to 25.4mm in diameter).

### 1ST CHAIR THRONE BASE -HYDRAULIX-



#### HSB5N

\*Seat holder included.

You can improve your existing throne or seat by changing the legs to one of the 1st Chair individual throne bases. The Hydraulix throne base comes with a seat holder with an adjustment lever.

### 1ST CHAIR THRONE BASE -Quartet-



#### HSB4N

You can improve your existing throne or seat by changing the legs to one of the 1st Chair individual throne bases. (diameter of upper rods: 22.2mm).

### 1ST CHAIR THRONE BASE -Trio-



#### HSB3N

You can improve your existing throne or seat by changing the legs to one of the 1st Chair individual throne bases. (diameter of upper rods: 22.2mm).

### 1ST CHAIR THRONE BASE -Trio-



#### HSB3

for Round Rider Series

You can improve your existing throne or seat by changing the legs to one of the 1st Chair individual throne bases. (diameter of upper rods: 22.2mm).

### 1ST CHAIR BACKREST ATTACHMENT



#### HTB5B

for any 1st Chair thrones

Sitting on a throne for a long period of time is tough on your back. The HTB5B can be adjusted up and down AND forward AND it can be detached from the seat when the gig is done. Slick!

## MEMORY LOCKS



**ML11**

for 10.5mm diameter L-rod



**ML12**

for 10.5-12mm diameter boom arm



**ML191C**

for 19.1mm diameter pipe



**ML191N**

for 19.1mm diameter pipe



**ML222C**

for 22.2mm diameter pipe



**ML222NT**

for 22.2mm diameter pipe



**ML254TC**

for 25.4mm diameter pipe



**ML254C**

for 25.4mm diameter pipe



**ML28C**

for 28.6mm diameter pipe

## QUICK-SET CYMBAL MATE



**QC8**  
(M8)

## QUICK-SET CYMBAL MATE (4pcs/set)



**QC8-B4**  
(M8: 4pcs/pack)

## CYMBAL MATE



**CM8P**  
(M8: 2pcs/pack)

## RING-TRUE FELT for STAR Hardware



**RTF35P**  
(2pcs/pack)

## FELT WASHER



**7081P**  
(2pcs/pack)

## HI-HAT CLUTCH FELT WASHERS



**CL08-13P**  
(2pcs/pack)

## REVERSIBLE CYMBAL BOTTOM



**RB8P**  
(M8: 2pcs/pack)

## STAR HARDWARE CYMBAL BOTTOM



**CB8P**  
(M8: 2pcs/pack)

## CYMBAL PROTECTION SLEEVE



**CPS8P**  
(M8: 2pcs/pack)

## HAT STACK



### CSH5

- Easily attach a small cymbal to hi-hat rod measuring up to 7mm in diameter
- Compact size and lightweight for easy transport and storage - 25mm (1") diameter x 40mm (1.5") height
- Ability to adjust cymbal sustain

## SIZZLE TOUCH DROP CLUTCH



### STDC7

TAMA's Sizzle Touch Drop Clutch allows you to adjust the gap between the top and bottom cymbals, allowing for fine adjustments to achieve the desired open sound.

## QUICK-SET HI-HAT CLUTCH



### QHC7

With just one touch, the Quick-Set Clutch can be attached or removed - simply push the button on the side of the clutch. (Fits 7mm or smaller diameter pull rod)

## SWING LOCK CLUTCH



### SLC08

This allows the top hi-hat cymbal to float more freely, maximizing the natural resonance of the cymbals. (Fits 6.3mm diameter pull rod)

## SECURITY CLUTCH



### CL08

Having your hi-hat clutch come loose is now a thing of the past with TAMA's Security Clutch. When the T-bolt is tightened, bottom lock nut and top section press on the rod for complete security. (Fits 6.3mm diameter pull rod)

## HI-HAT TENSION RODS



### HH905-3 HH905D3S

Tension Rod w/ Plastic Nut (M6)

HH905-3 (Long / 500mm (19 11/16"))  
HH905D3S (Short / 350mm (13 3/4"))

## REMOTE HI-HAT STAND CABLE



### HH905RH2L HH905RH2S

Exchangeable Cable for HH905RH

HH905RH2L (Long / 2,300mm (90 1/2"))  
HH905RH2S (Short / 1,200mm (47 1/4"))

## SOUND FOCUS PAD -for Cocktail-JAM- / Cocktail-JAM Mini



### SFP530

Bass Drum Mute for Cocktail-JAM kits

## TAMA SILICONE COASTER SET

NEW



### TCT10SD

-TAMA Snare drum shaped coaster set  
-4pcs/pack

## QUICK-LOCK TOM BRACKET



### MQMP-TCH

(for tom tom/Chrome)  
-Quick and easy setup in position  
-Enhanced resonance with rubber lining



### MQMP-TBN

(for tom tom/Black Nickel)  
-Quick and easy setup in position  
-Enhanced resonance with rubber lining



### MQMP-FCH

(for floor tom/Chrome)  
-Quick and easy setup in position  
-Enhanced resonance with rubber lining



### MQMP-FBN

(for floor tom/Black Nickel)  
-Quick and easy setup in position  
-Enhanced resonance with rubber lining

## MERCHANDISE



### TKC10LG

TAMA Logo Key Chain



**TAMA Logo Sticker White**  
TLS120WH 60mm x 280mm  
TLS100WH 50mm x 230mm  
TLS80WH 40mm x 190mm  
TLS70WH 35mm x 150mm



**TAMA Logo Sticker Black**  
TLS120BK 60mm x 280mm  
TLS100BK 50mm x 230mm  
TLS80BK 40mm x 190mm  
TLS70BK 35mm x 150mm



### TSM01

Sonic Mute (2pcs/set)  
Removable, reusable & reliable mute patch. Adjustable for optimum precision and control. (Wash lightly to restore adhesion).



### TAMH001

Available size: S/M/L/XL/XXL

TAMH001S  
TAMH001M  
TAMH001L  
TAMH001XL  
TAMH001XXL



### TAMT001

Available size: S/M/L/XL/XXL

TAMT001S  
TAMT001M  
TAMT001L  
TAMT001XL  
TAMT001XXL



### TAMT003

Available size: S/M/L/XL/XXL

TAMT003S  
TAMT003M  
TAMT003L  
TAMT003XL  
TAMT003XXL

# DRUM STICKS

MADE IN JAPAN

TAMA drum sticks are molded under strict quality control standards from carefully selected wood materials and are renowned for their consistent high quality.

## ORIGINAL SERIES STICK -Japanese Oak-



### TAMA-0213B

Diameter: 7A, 13mm (0.510")  
Length: 406mm (16")  
Tip Style: Ball

### TAMA-0214B

Diameter: 5A, 14mm (0.550")  
Length: 406mm (16")  
Tip Style: Ball

### TAMA-0215B

Diameter: 5B, 15mm (0.590")  
Length: 406mm (16")  
Tip Style: Ball

### TAMA-0216B

Diameter: 2B, 16mm (0.630")  
Length: 406mm (16")  
Tip Style: Ball



### TAMA-0213P

Diameter: 7A, 13mm (0.510")  
Length: 406mm (16")  
Tip Style: Popular

### TAMA-0214P

Diameter: 5A, 14mm (0.550")  
Length: 406mm (16")  
Tip Style: Popular

### TAMA-0215P

Diameter: 5B, 15mm (0.590")  
Length: 406mm (16")  
Tip Style: Popular



### TAMA-0214S

Diameter: 5A, 14mm (0.550")  
Length: 406mm (16")  
Tip Style: Small

### TAMA-0215S

Diameter: 5B, 15mm (0.590")  
Length: 406mm (16")  
Tip Style: Small

## TRADITIONAL SERIES STICK -JAPANESE OAK-



### TAMA-07AW

Diameter: 7A, 13mm (0.510")  
Length: 390mm (15 3/8")  
Tip Style: 7A



### TAMA-07AN

Diameter: 7A, 13mm (0.510")  
Length: 390mm (15 3/8")  
Tip Style: 7A (Nylon)



### TAMA-05AW

Diameter: 5A, 14mm (0.550")  
Length: 406mm (16")  
Tip Style: 5A



### TAMA-05AN

Diameter: 5A, 14mm (0.550")  
Length: 406mm (16")  
Tip Style: 5A (Nylon)



### TAMA-08AW

Diameter: 8A, 14mm (0.550")  
Length: 406mm (16")  
Tip Style: 8A



### TAMA-05BW

Diameter: 5B, 15mm (0.590")  
Length: 406mm (16")  
Tip Style: 5B



### TAMA-05BN

Diameter: 5B, 15mm (0.590")  
Length: 406mm (16")  
Tip Style: 5B (Nylon)

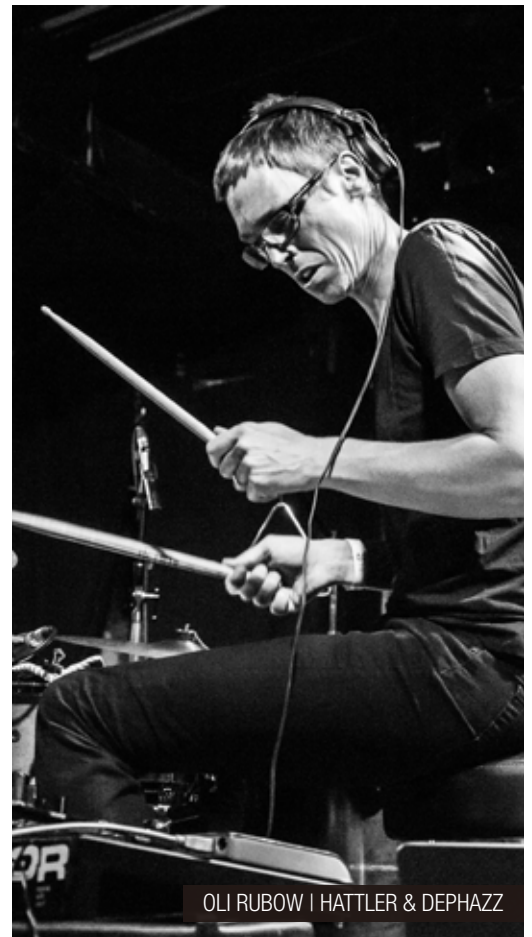

OLI RUBOW | HATTLER & DEPHAZZ

## TRADITIONAL SERIES STICK -American Hickory-



### TAMA-H7AW

Diameter: 7A, 13mm (0.510")  
Length: 390mm (15 3/8")  
Tip Style: 7A



### TAMA-H5AW

Diameter: 5A, 14mm (0.550")  
Length: 406mm (16")  
Tip Style: 5A



### TAMA-H8AW

Diameter: 8A, 14mm (0.550")  
Length: 406mm (16")  
Tip Style: 8A



### TAMA-H5BW

Diameter: 5B, 15mm (0.590")  
Length: 406mm (16")  
Tip Style: 5B

## GRIP WRAP

NEW



### TGW10BK

MADE IN JAPAN

(2prs / set)

TAMA's Grip Wrap is designed to provide the player with a comfortable, non-slip surface for their drumsticks.

- Non-Slip Surface
- Soft and Comfortable Feel
- Highly Durable Material Made in Japan

## OAK LAB SERIES -Smash-



### OL-SM

- SMASH -  
Weight and balance for huge power.

Diameter: 5B, 15mm (0.590")  
Length: 419mm (16 1/2")  
Tip Style: Acorn



### OL-RE

-RESONATOR -  
Heavy for rich tones. Quick rebound.

Diameter: 5B, 15.25mm (0.600")  
Length: 410mm (16 5/32")  
Tip Style: Arrow



### OL-FA

- FAST BLAST -  
(Natural / Uncoated)  
Modified 5A for more speed. Large tip and Oak enhances volume.

Diameter: 5A, 14mm (0.550")  
Length: 406mm (16")  
Tip Style: Large Ball



### OL-SW

- SWINGIN' -  
Oak provides a bright cymbal tone and enhanced cross stick sound.

Diameter: 7A, 12.75mm (0.500")  
Length: 403mm (15 7/8")  
Tip Style: Oval



### OL-FU

- FULL BALANCE -  
Weighted for accuracy and control.

Diameter: 5A, 14.5mm (0.570")  
Length: 406mm (16")  
Tip Style: True Round

## SUEDE-GRIP DRUM STICKS -Japanese Oak-

Suede-Grip drum sticks are coated with a special non-slip, slightly flexible paint.

MADE IN JAPAN



### TAMA-O-5A-SG

(SUEDE-GRIP Finish)

Diameter : 5A, 14mm (0.550")  
Length : 406mm (16")  
Tip Style : 5A



### TAMA-O-5B-SG

(SUEDE-GRIP Finish)

Diameter : 5B, 15mm (0.590")  
Length : 406mm (16")  
Tip Style : 5B

## REDZONE -Japanese Oak-



### TAMA-O5ARZ

(Silver Logo)

Diameter: 5A, 14mm (0.550")  
Length: 419mm (16 1/2")  
Tip Style: 5A (Nylon)

### TAMA-O5BRZ

(Silver Logo)

Diameter: 5B, 15mm (0.590")  
Length: 419mm (16 1/2")  
Tip Style: 5B (Nylon)

## RHYTHMIC FIRE -Japanese Oak-



### TAMA-O7A-F

(Natural)

Diameter: 7A, 13mm (0.510")  
Length: 390mm (15 3/8")  
Tip Style: 7A

### TAMA-O5A-F

(Natural)

Diameter: 5A, 14mm (0.550")  
Length: 406mm (16")  
Tip Style: 5A

### TAMA-O5B-F

(Natural)

Diameter: 5B, 15mm (0.590")  
Length: 406mm (16")  
Tip Style: 5B



### TAMA-O7A-F-BS

(Black, Silver Pattern)

Diameter: 13mm (0.510")  
Length: 390mm (15 3/8")  
Tip Style: 7A

### TAMA-O5A-F-BS

(Black, Silver Pattern)

Diameter: 14mm (0.550")  
Length: 406mm (16")  
Tip Style: 5A

### TAMA-O5B-F-BS

(Black, Silver Pattern)

Diameter: 5B, 15mm (0.590")  
Length: 406mm (16")  
Tip Style: 5B



### TAMA-O7A-F-BR

(Black, Red Pattern)

Diameter: 7A, 13mm (0.510")  
Length: 390mm (15 3/8")  
Tip Style: 7A

### TAMA-O5A-F-BR

(Black, Red Pattern)

Diameter: 5A, 14mm (0.550")  
Length: 406mm (16")  
Tip Style: 5A

### TAMA-O5B-F-BR

(Black, Red Pattern)

Diameter: 5B, 15mm (0.590")  
Length: 406mm (16")  
Tip Style: 5B

## STICKS OF DOOM -Japanese Oak-



### TAMA-O7A-S

(Natural)

Diameter: 7A, 13mm (0.510")  
Length: 390mm (15 3/8")  
Tip Style: 7A

### TAMA-O5A-S

(Natural)

Diameter: 5A, 14mm (0.550")  
Length: 406mm (16")  
Tip Style: 5A

### TAMA-O5B-S

(Natural)

Diameter: 5B, 15mm (0.590")  
Length: 406mm (16")  
Tip Style: 5B



### TAMA-O7A-S-BS

(Black, Silver Pattern)

Diameter: 7A, 13mm (0.510")  
Length: 390mm (15 3/8")  
Tip Style: 7A

### TAMA-O5A-S-BS

(Black, Silver Pattern)

Diameter: 5A, 14mm (0.550")  
Length: 406mm (16")  
Tip Style: 5A

### TAMA-O5B-S-BS

(Black, Silver Pattern)

Diameter: 5B, 15mm (0.590")  
Length: 406mm (16")  
Tip Style: 5B



## SIGNATURE MODELS

### DIRK VERBEUREN MODEL -Japanese Oak-



#### TAMA-O-DVM

Dirk Verbeuren (MEGADETH)

Diameter: 16mm (0.630")  
Length: 406mm (16")

### JEREMY COLSON MODEL -American Hickory-



#### TAMA-H-JCS

Jeremy Colson (Steve Vai)

Diameter: 16.5mm (0.649")  
Length: 422mm (16.6")

### MARIO DUPLANTIER MODEL -American Hickory-



#### TAMA-H-MD

Mario Duplantier (Gojira)

Diameter: 16.5mm (0.649")  
Length: 432mm (17")

### ALEX RUDINGER MODEL -American Hickory-



#### TAMA-H-RUDI

Alex Rudinger

Diameter: 16mm (0.630")  
Length: 416mm (16 3/8")  
Non-Slipping Lacquer Finish

### ANUP SASTRY MODEL -American Hickory-



#### TAMA-H-AS

Anup Sastry

Diameter: 16mm (0.630")  
Length: 432mm (17")

### YOSHIKI MODEL -American Hickory-



#### TAMA-H-YKB

YOSHIKI (X-JAPAN / VIOLET UK)

Diameter: 14.25mm (0.561")  
Length: 398mm (15 5/8")

# MARCHING PERCUSSION

After a long period of planning and experimentation, TAMA Marching Percussion is finally complete. High durability, various unique features for function and comfort, and revolutionary improvements allow total customized playability for everyone.

## PREMIUM MARCHING SNARE DRUMS



Color: Dark Stardust Fade (DSF)

### M1409SL

- Shell : Maple 6ply 5mm
- Hoop : Aluminum die-cast hoop
- Number of Lugs : 12 lugs with aluminum tube pipes
- Strainer : High Position strainer
- Batter Side Edge Ring : Aluminum die-cast edge ring for super high-pitch tuning
- Bottom Side Edge : With reinforcement ring
- 11 Yellow Hard Guts with Detachable Gut Frame
- 2 Buzz Killer Mutes included

### Lacquer Finishes

Model No.	Size		
M1409SL	9"x14" MARCHING SNARE DRUM		
M1412SL	12"x14" MARCHING SNARE DRUM		

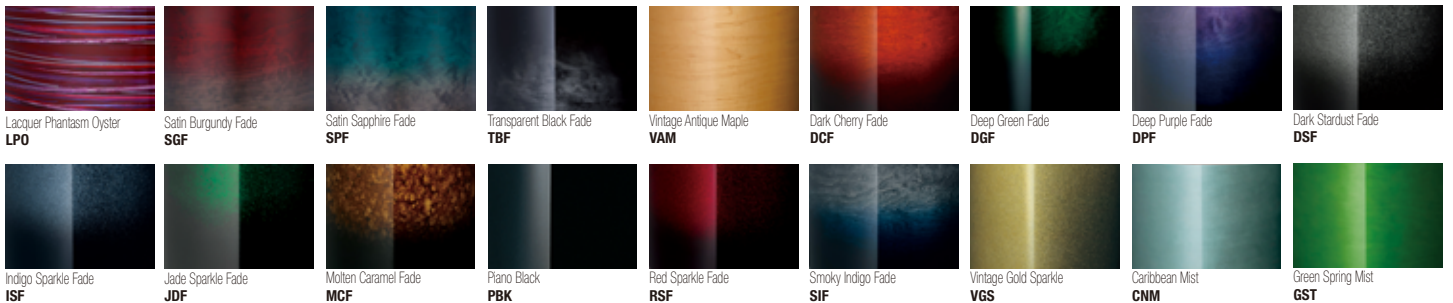

### Lacquer Finish -Satin Black-

Model No.	Size		
M1409ST	9"x14" MARCHING SNARE DRUM		
M1412ST	12"x14" MARCHING SNARE DRUM		



Satin Black  
**SBK**

### Wrap Finish -Sugar White-

Model No.	Size		
M1409SK	9"x14" MARCHING SNARE DRUM		
M1412SK	12"x14" MARCHING SNARE DRUM		



Sugar White  
**SGW**

# PREMIUM MARCHING TENOR DRUMS



## M680234TL

- Shell : Maple Gply 5mm
- Hoop : 2.3 mm Steel Mighty Hoop
- Adjusting Tom Angle : Adjusts by loosening 4 screws with tuning key
- Legs : Three Detachable legs included
- Edge Guard Included

Color: Molten Caramel Fade (CMF)

### Lacquer Finishes

Model No.	Size		
M8023TL	8"-10"-12"-13" QUAD DRUMS		
M68023TL	6"-8"-10"-12"-13" QUINT DRUMS		
M668023TL	6"-6"-8"-10"-12"-13" SEXTET DRUMS		
M0234TL	10"-12"-13"-14" QUAD DRUMS		
M60234TL	6"-10"-12"-13"-14" QUINT DRUMS		
M60234DL	6"-10"-12"-13"-14" QUINT DRUMS (CORP-DEPTH)		
M80234TL	8"-10"-12"-13"-14" QUINT DRUMS		
M660234TL	6"-6"-10"-12"-13"-14" SEXTET DRUMS		
M660234DL	6"-6"-10"-12"-13"-14" SEXTET DRUMS (CORP-DEPTH)		
M680234TL	6"-8"-10"-12"-13"-14" SEXTET DRUMS		
M680234DL	6"-8"-10"-12"-13"-14" SEXTET DRUMS (CORP-DEPTH)		
M602TL	6"-10"-12" TRIO DRUMS		
M4TL	11.5"x14" SOLO TENOR DRUM		



Lacquer Phantasm Oyster  
**LPO**

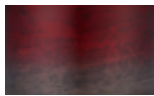

Satin Burgundy Fade  
**SGF**



Satin Sapphire Fade  
**SPF**

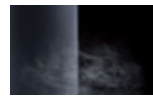

Transparent Black Fade  
**TBF**



Vintage Antique Maple  
**VAM**



Dark Cherry Fade  
**DCF**



Deep Green Fade  
**DGF**

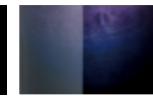

Deep Purple Fade  
**DPF**

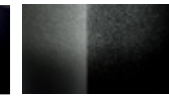

Dark Stardust Fade  
**DSF**



Indigo Sparkle Fade  
**ISF**

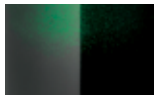

Jade Sparkle Fade  
**JDF**

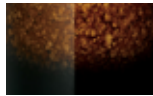

Molten Caramel Fade  
**MCF**



Piano Black  
**PBK**



Red Sparkle Fade  
**RSF**

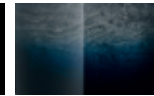

Smoky Indigo Fade  
**SIF**



Vintage Gold Sparkle  
**VGS**



Caribbean Mist  
**CNM**



Green Spring Mist  
**GSM**

### Lacquer Finish -Satin Black-

Model No.	Size		
M8023TT	8"-10"-12"-13" QUAD DRUMS		
M68023TT	6"-8"-10"-12"-13" QUINT DRUMS		
M668023TT	6"-6"-8"-10"-12"-13" SEXTET DRUMS		
M0234TT	10"-12"-13"-14" QUAD DRUMS		
M60234TT	6"-10"-12"-13"-14" QUINT DRUMS		
M60234DT	6"-10"-12"-13"-14" QUINT DRUMS (CORP-DEPTH)		
M80234TT	8"-10"-12"-13"-14" QUINT DRUMS		
M660234TT	6"-6"-10"-12"-13"-14" SEXTET DRUMS		
M660234DT	6"-6"-10"-12"-13"-14" SEXTET DRUMS (CORP-DEPTH)		
M680234TT	6"-8"-10"-12"-13"-14" SEXTET DRUMS		
M680234DT	6"-8"-10"-12"-13"-14" SEXTET DRUMS (CORP-DEPTH)		
M602TT	6"-10"-12" TRIO DRUMS		
M4TT	11.5"x14" SOLO TENOR DRUM		



Satin Black  
**SBK**

### Wrap Finish -Sugar White-

Model No.	Size		
M8023TK	8"-10"-12"-13" QUAD DRUMS		
M68023TK	6"-8"-10"-12"-13" QUINT DRUMS		
M668023TK	6"-6"-8"-10"-12"-13" SEXTET DRUMS		
M0234TK	10"-12"-13"-14" QUAD DRUMS		
M60234TK	6"-10"-12"-13"-14" QUINT DRUMS		
M60234DK	6"-10"-12"-13"-14" QUINT DRUMS (CORP-DEPTH)		
M80234TK	8"-10"-12"-13"-14" QUINT DRUMS		
M660234TK	6"-6"-10"-12"-13"-14" SEXTET DRUMS		
M660234DK	6"-6"-10"-12"-13"-14" SEXTET DRUMS (CORP-DEPTH)		
M680234TK	6"-8"-10"-12"-13"-14" SEXTET DRUMS		
M680234DK	6"-8"-10"-12"-13"-14" SEXTET DRUMS (CORP-DEPTH)		
M602TK	6"-10"-12" TRIO DRUMS		
M4TK	11.5"x14" SOLO TENOR DRUM		



Sugar White  
**SGW**

# PREMIUM MARCHING BASS DRUMS



Color: Dark Stardust Burst (DSD)

## M2214BL

- Shell : Maple 8ply 6mm
- Attachment for carrier : Noiseless carrier attachment
- Locking attachment for stand : 18" - 30" bass drums have other attachment. 14" & 16" bass drum can be locked with Noiseless carrier attachment.
- Lug : Die-cast aluminum high-tension lugs
- Number of lugs : 14" - 18" = 8 lugs, 20" - 28" = 10 lugs, 30" = 12 lugs
- Claw Hook : Designed with superior strength for high-pitch tuning
- Hoop : High-gloss black lacquer finish

### Lacquer Finishes

Model No.	Size		
M1414BL	14"x14" MARCHING BASS DRUM		
M1614BL	14"x16" MARCHING BASS DRUM		
M1814BL	14"x18" MARCHING BASS DRUM		
M2014BL	14"x20" MARCHING BASS DRUM		
M2214BL	14"x22" MARCHING BASS DRUM		
M2414BL	14"x24" MARCHING BASS DRUM		
M2614BL	14"x26" MARCHING BASS DRUM		
M2814BL	14"x28" MARCHING BASS DRUM		
M3016BL	16"x30" MARCHING BASS DRUM w/o drum heads		



### Lacquer Finishes -Satin Black-

Model No.	Size		
M1414BT	14"x14" MARCHING BASS DRUM		
M1614BT	14"x16" MARCHING BASS DRUM		
M1814BT	14"x18" MARCHING BASS DRUM		
M2014BT	14"x20" MARCHING BASS DRUM		
M2214BT	14"x22" MARCHING BASS DRUM		
M2414BT	14"x24" MARCHING BASS DRUM		
M2614BT	14"x26" MARCHING BASS DRUM		
M2814BT	14"x28" MARCHING BASS DRUM		
M3016BT	16"x30" MARCHING BASS DRUM w/o drum heads		



### Wrap Finish -Sugar White-

Model No.	Size		
M1414BK	14"x14" MARCHING BASS DRUM		
M1614BK	14"x16" MARCHING BASS DRUM		
M1814BK	14"x18" MARCHING BASS DRUM		
M2014BK	14"x20" MARCHING BASS DRUM		
M2214BK	14"x22" MARCHING BASS DRUM		
M2414BK	14"x24" MARCHING BASS DRUM		
M2614BK	14"x26" MARCHING BASS DRUM		
M2814BK	14"x28" MARCHING BASS DRUM		
M3016BK	16"x30" MARCHING BASS DRUM w/o drum heads		



## STARLIGHT MARCHING SNARE DRUMS



Color: Satin Black (SBK)

### R1412SL

- Shell : Birch 8ply 8mm
- Hoop : 2.3mm Steel Mighty Hoop
- Number of Lugs : 12 lugs with aluminum tube pipes
- Strainer : Quick touch snare strainer
- Snare Wires : 20-strand Carbon Steel Snappy Snares

#### Lacquer Finish -Satin Black-

Model No.	Size		
R1412SL	12"x14" MARCHING SNARE DRUM		

Satin Black  
SBK

#### Wrap Finish -Sugar White-

Model No.	Size		
R1412SK	12"x14" MARCHING SNARE DRUM		

Sugar White  
SGW

## STARLIGHT MARCHING TENOR DRUMS



Color: Sugar White (SGW)

### R8023TL

- Shell : Birch 8ply 8mm
- Hoop : 1.6mm Steel Triple Flanged Hoop
- Hardware Finish : Chrome hardware finish is standard
- Adjustable Tom Angle (Quad)
- Edge Guard included

#### Lacquer Finish -Satin Black-

Model No.	Size		
R8023TL	8"-10"-12"-13" QUAD DRUMS		
R802TL	8"-10"-12" TRIO DRUMS		
R4TL	11.5"x14" SOLO TENOR DRUM		
R0655TLP	5.5"x6" TOM FOR TENOR DRUM		

#### Wrap Finish -Sugar White-

Model No.	Size		
R8023TK	8"-10"-12"-13" QUAD DRUMS		
R802TK	8"-10"-12" TRIO DRUMS		
R4TK	11.5"x14" SOLO TENOR DRUM		
R0655TKP	5.5"x6" TOM FOR TENOR DRUM		



Satin Black  
SBK



Sugar White  
SGW

## STARLIGHT MARCHING BASS DRUMS



Color: Sugar White (SGW)

### R2214BL

- Shell : Birch 7ply 7mm
- Attachment for carrier : Noiseless carrier attachment
- Lug : Die-cast aluminum high-tension lugs with chrome finish
- Number of lugs : 16" - 18" = 8 lugs, 20" - 28" = 10 lugs
- Claw Hook : Designed with superior strength for high-pitch tuning
- Hoop : High-gloss black lacquer finish

#### Lacquer Finish -Satin Black-

Model No.	Size		
R1614BL	14"x16" MARCHING BASS DRUM		
R1814BL	14"x18" MARCHING BASS DRUM		
R2014BL	14"x20" MARCHING BASS DRUM		
R2214BL	14"x22" MARCHING BASS DRUM		
R2414BL	14"x24" MARCHING BASS DRUM		
R2614BL	14"x26" MARCHING BASS DRUM		
R2814BL	14"x28" MARCHING BASS DRUM		

#### Wrap Finish -Sugar White-

Model No.	Size		
R1614BK	14"x16" MARCHING BASS DRUM		
R1814BK	14"x18" MARCHING BASS DRUM		
R2014BK	14"x20" MARCHING BASS DRUM		
R2214BK	14"x22" MARCHING BASS DRUM		
R2414BK	14"x24" MARCHING BASS DRUM		
R2614BK	14"x26" MARCHING BASS DRUM		
R2814BK	14"x28" MARCHING BASS DRUM		



Satin Black  
SBK



Sugar White  
SGW

## SILVER ARMOR CARRIER FOR SNARE DRUM



### CSASDT

- Sliding Height Adjustment
- Safety Lock Mount
- Positioning Bar
- Belly Pad
- Shoulder Pipe Adjustment
- Backrest Adjustment
- Movable Pad

## SILVER ARMOR CARRIER FOR TENOR DRUM



### CSATNT

- Sliding Height Adjustment
- Safety Lock Mount
- Positioning Bar
- Drum Lift Bumper
- Belly Pad
- Shoulder Pipe Adjustment
- Backrest Adjustment
- Movable Pad

## SILVER ARMOR CARRIER FOR BASS DRUM



### CSABDT

- Sliding Height Adjustment
- Safety Lock Mount
- Two-way Support Bar
- Belly Pad
- Shoulder Pipe Adjustment
- Backrest Adjustment
- Movable Pad

## SILVER ARMOR CARRIER "J-BAR TYPE" FOR SNARE DRUM



### CSASDM

- Sliding Height Adjustment
- Belly Pad
- Shoulder Pipe Adjustment
- Backrest Adjustment
- Movable Pad

## SILVER ARMOR CARRIER "J-BAR TYPE" FOR TENOR DRUM



### CSATNM

- Sliding Height Adjustment
- Drum Lift Bumper
- Belly Pad
- Shoulder Pipe Adjustment
- Backrest Adjustment
- Movable Pad

## SILVER ARMOR CARRIER "HOOK TYPE" FOR BASS DRUM



### CSABDM

- Sliding Height Adjustment
- Two-way Support Bar
- Belly Pad
- Shoulder Pipe Adjustment
- Backrest Adjustment
- Movable Pad

## STARLIGHT CARRIER FOR SNARE DRUM



### CRSDT

- Sliding Height Adjustment
- Safety Lock Mount

## STARLIGHT CARRIER FOR TENOR DRUM



### CRTNT

- Sliding Height Adjustment
- Safety Lock Mount

## STARLIGHT CARRIER FOR BASS DRUM



### CRBDT

- Sliding Height Adjustment
- Safety Lock Mount
- Two-way Support Bar

## SAFETY LOCK MARCHING STAND FOR SNARE DRUM



### HMSD79WSN

- Snare Anti-Shake Bumper
- Upside Down Setting
- Safety Lock Mount
- Center of Gravity Position
- Adjustable 2 Front Legs

## SAFETY LOCK MARCHING STAND FOR TENOR DRUM



**HMTN79WSN**  
 -Fold and Positioning Bar  
 -Tenor Anti-Chace Support Bar  
 -Safety Lock Mount  
 -Center of Gravity Position  
 -Adjustable 2 Front Legs

## SAFETY LOCK MARCHING STAND FOR BASS DRUM



**HMBD79WSN**  
 -Center of Gravity Position  
 -Adjustable 2 Front Legs

## SAFETY LOCK MARCHING NON STADIUM STAND FOR SNARE DRUM



**HMSD79WN**  
 -Snare Anti-Shake Bumper  
 -Upside Down Setting  
 -Safety Lock Mount  
 -Center of Gravity Position

## SAFETY LOCK MARCHING NON STADIUM STAND FOR TENOR DRUM



**HMTN79WN**  
 -Fold and Positioning Bar  
 -Tenor Anti-Shake Support Bar  
 -Safety Lock Mount  
 -Center of Gravity Position

## SAFETY LOCK MARCHING NON STADIUM STAND FOR BASS DRUM



**HMBD79WN**  
 -Center of Gravity Position

## MARCHING DRUM PROTECT COVERS FOR SNARE DRUM



**CVS1412**  
 CVS1412 (for 12"x14" Snare Drum)

## MARCHING DRUM PROTECT COVERS FOR TENOR DRUM



**CVTL**  
 CVTL (Large Size)

## MARCHING DRUM PROTECT COVERS FOR BASS DRUM



**CVB2224**  
 CVB1416 (for 14"x16" Bass Drum)  
 CVB1820 (for 18"x20" Bass Drum)  
 CVB2224 (for 22"x24" Bass Drum)  
 CVB2628 (for 26"x28" Bass Drum)

## HOOP GRIP & Z-ROD FOR HI-HAT CYMBALS



**MC8ZHH**  
 Hoop Grip (MC8) & Z-Rod for Hi-Hat Cymbals (ZHH) bundle package

## Z-ROD FOR HI-HAT CYMBALS



**ZHH**  
 Z-rod for mounting Hi-Hat cymbals  
 Details:  
 - Screw Type Hi-Hat Clutch

## SNARE PROJECTER



### TPS14W

For 14" Snare Drums

TPS14W (White)  
TPS14B2 (Black)  
TPS14C (Clear)

## BASS DRUM HOOP GUARD



### MBRG14

TAMA Hoop Guards can be securely locked to bass drum hoops using the friction of rubber cushions. The rubber cushions protect the hoops from scratches and the Hoop Guards protect the hoops from rim shots.

## SNARE MUTE



### MSMT

## HARD GUT FRAME ASSEMBLY



### MGF14HD

TAMA Yellow Hard Guts are relatively harder than standard guts and produce a crisper and brighter sound. The gut frame can be instantly changed to produce the sound of your choice.

## MULTI LOCK CLAMP



### MLC79

## BASS DRUM MUFFLE RINGS



### MBSP2

(2pcs/set)

## BACK SUPPORT BELT FOR CARRIER



### CSABSB

The Back Support Belt gives extra support while reducing back stress. Designed to be used with TAMA Silver Armor Carriers, (sold separately), it can be easily adjusted for different body types and is removable.

## TURNING KEY

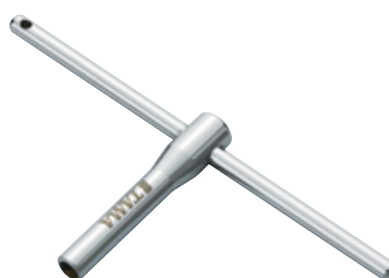

### THDK20

Hi-Tension Tuning Key

## TAMA LOGO STICKER -White-



### TLS100WH

TLS120WH 60mm x 280mm  
TLS100WH 50mm x 230mm  
TLS80WH 40mm x 190mm  
TLS70WH 35mm x 150mm

## TAMA LOGO STICKER -Black-



### TLS100BK

TLS120BK 60mm x 280mm  
TLS100BK 50mm x 230mm  
TLS80BK 40mm x 190mm  
TLS70BK 35mm x 150mm



# CONCERT PERCUSSION

We offer Concert Percussion lineup with snare drums, toms, and hardwares. STARPHONIC Concert Snare Drums are built to the absolute pinnacle of quality and design, and they carry a sound that's to be expected from any instrument bearing the name TAMA.

## CONCERT SNARE DRUMS - STARPHONIC BRAVURA



**CMP146MF** MADE IN JAPAN  
 Shell: 6mm, 7ply 100% Maple  
 Size: 6"x14"  
 Lug: Freedom Lug  
 Hoop: Grooved Straight Hoop (10 hole)  
 Strainer: MUS50AC w/Multi Snare Frame  
 Butt: MUS50AB w/Multi Snare Frame  
 Snare Wire:  
 Nickel Wound Round Guitar String (6 strands)  
 Black Nylon Coated Stainless Steel Wire (6 strands)  
 Hi-Carbon Coil Snare Wire (6 strands)  
 Color: Piano Black (PBK), Gloss Mocha Brown (GMC)

## CONCERT SNARE DRUMS - STARPHONIC



**CMP146** MADE IN JAPAN  
 Shell: 6mm, 7ply 100% Maple  
 Size: 6"x14"  
 Lug: Freedom Lug  
 Hoop: Grooved Straight Hoop (10 hole)  
 Strainer: MUS50A Linear Drive Strainer  
 Butt: MUS50B  
 Snare Wire: Hybrid Snare Wire  
 Nickel Wound Round Guitar String (6 strands in the center)  
 Black Nylon Coated Stainless Steel Wire (3 strands each outside)  
 Color: Piano Black (PBK), Gloss Cherry Red (GCR)

## CONCERT TOM SET



**CCLT4H**  
 High-Pitched Concert Tom Set  
 6"x6" Tom Tom, 8"x7" Tom Tom, 10"x8" Tom Tom, 12"x9" Tom Tom  
 - 100% Maple Shell  
 - Direct-Flexi Mount

## CONCERT TOM SET



**CCLT4M**  
 Mid-Pitched Concert Tom Set  
 10"x8" Tom Tom, 12"x9" Tom Tom, 13"x11" Tom Tom, 14"x12" Tom Tom  
 - 100% Maple Shell  
 - Direct-Flexi Mount

## CONCERT TOM SET



**CCLT4L**  
 Low-Pitched Concert Tom Set  
 12"x10" Tom Tom, 13"x11" Tom Tom, 14"x12" Tom Tom, 16"x13" Tom Tom  
 - 100% Maple Shell  
 - Direct-Flexi Mount

## CONCERT TOM - Single



**CCLT6A** 6"x06" Tom Tom  
**CCLT8A** 8"x07" Tom Tom  
**CCLT10A** 10"x08" Tom Tom  
**CCLT12A** 12"x09" Tom Tom  
**CCLT12D** 12"x10" Tom Tom  
**CCLT13D** 13"x11" Tom Tom  
**CCLT14D** 14"x12" Tom Tom  
**CCLT16D** 16"x13" Tom Tom

## CONCERT TOM SET -SINGLE HEAD-

**NEW**



**CSLT4H**  
 High-Pitched Concert Tom Set  
 6"x6" Tom Tom, 8"x7" Tom Tom, 10"x8" Tom Tom, 12"x9" Tom Tom  
 - 100% Maple Shell  
 - Direct-Flexi Mount  
 [Available Finishes]  
 -Vintage Antique Maple (VAM)  
 -Transparent Black Fade (TBF)

Color: Vintage Antique Maple -VAM-

## CONCERT TOM SET -SINGLE HEAD-

**NEW**



**CSLT4M**  
 Mid-Pitched Concert Tom Set  
 10"x8" Tom Tom, 12"x9" Tom Tom, 13"x11" Tom Tom, 14"x12" Tom Tom  
 - 100% Maple Shell  
 - Direct-Flexi Mount  
 [Available Finishes]  
 -Vintage Antique Maple (VAM)  
 -Transparent Black Fade (TBF)

Color: Vintage Antique Maple -VAM-

**NEW**

### CONCERT TOM SET -SINGLE HEAD-



Color: Vintage Antique Maple -VAM-

#### CSLT4L

Low-Pitched Concert Tom Set  
12"x10" Tom Tom, 13"x11" Tom Tom,  
14"x12" Tom Tom, 16"x13" Tom Tom

- 100% Maple Shell
- Direct-Flexi Mount

[Available Finishes]  
 -Vintage Antique Maple (VAM)  
 -Transparent Black Fade (TBF)

**NEW**

### CONCERT TOM -SINGLE HEAD-



Color: Vintage Antique Maple -VAM-

#### CSLT6A

6"x6" Tom Tom

#### CSLT8A

8"x7" Tom Tom

#### CSLT10A

10"x8" Tom Tom

#### CSLT12A

12"x9" Tom Tom

#### CSLT12D

12"x10" Tom Tom

#### CSLT13D

13"x11" Tom Tom

#### CSLT14D

14"x12" Tom Tom

#### CSLT16D

16"x13" Tom Tom

Also available in:  
 -Transparent Black Fade (TBF)

### CONCERT SNARE STAND - ROADPRO



#### HS80HWN

For 12" to 15" Diameter Snare Drums

- Quick-Set Tilter
- Swiveling Basket
- Glide-Tite Grip Joint
- Double Braced Legs
- Weight: 3.7kg (8.2lbs)
- Height Adjustment Range: 640mm - 925mm (25 3/16" - 36 3/8")

### CONCERT SNARE STAND - THE CLASSIC STAND



#### HS50HF

-Flat Base Leg Design

- Classic Style Basket
- Double Braced Arms
- Gearless Tilter
- Weight: 1.9kg (4.2lbs)
- Height Adjustment Range: 630mm-860mm (24 13/16" - 33 7/8")

### DOUBLE TOM STAND



#### HTW839W

-28.6mm Diameter Base Section Tubing

- Omni-Ball Tom Angle Adjustment
- Still System
- Glide-Tite Grip Joint
- Double Braced Legs
- Weight: 5.0kg (11lbs)



FABIO DUWENTESTER | MAX RAABE & PALASTORCHESTER

# MANY THANKS TO FURTHER ARTISTS

Alex Hoetzing | Theater des Westens

Ali Zieme | Die Prinzen

Christian Einheller | Rainhard Fendrich

Christian Fritz | Nasty

Christian Hülsmann | Freelance

Christian Tournay | Freelance

Christoph Liening | Wirtz

Christoph Rosenplänter | Feuerengel

Christoph Schneider | Antilopen Gang

Cornelius Ulrich | MEUTE

Dominique Ehlert | Hot 'n' Nasty & Dark Suns

Thomas Fietz | Milky Chance

Florian Rein | Bananafishbones

Gustav Schäfer | Tokio Hotel

Hajo Von Hadeln | Freelance

Hubert Bründlmayer | Freelance

Leon Stiller | Any Given Day

Manuel Hermann | Freelance

Marcel Gustke | Superflow & WDR Big Band

Markus Matzinger | Implore

Markus Freiwald | Bonded & Despair

Martin Potthoff | Unheilig

Martin Stöck | Freelance

Matthias "Maze" Meusel | Freelance

Oliver Steidle | Soko Steidle

Peter Wrba | Freelance

Ramy Ali | Serious Black & Iron Mask

Robert Memmler | Bodo Wartke

Robin McMinn | MEUTE

Roland Navratil | Freelance

Sebastian Heldt | Neaera

Simon Schröder | Freelance

Thomas Caser | Visions Of Atlantis

Tim Hahn | Klazz Brothers

Timo Gleichmann | Saltatio Mortis

Tobias Mertens | Freelance

Tobias Nessel | Chris Cosmo

Tobias Schulte | Edgar Knecht Trio

Tommy Fischer | Freelance

Vincent Golly | Pimpypanda

Wolf Simon | Freelance

# Photo Credits

Andi Brügge | Jessika Wollstein

Anika Nilles | Mario Schmitt

Ansgar Freyberg | Philip Scholl

Bastian Emig | Tim Tronckoe

Christin Neddens | Gerhard Kühne

Dániel Gerendás | David Bodnar

Dariusz "Daray" Brzozowski | Maciej Pieloch

David Diepold | Manuel Diepold

Fabian Füss | Angela Regenbrecht

Fabio Duwentester | Paulin Tom Pintsch

Flo Dauner & Oli Rubow & Specki T.D. | Nalan Music Art Photography

Flo König | Danny Jungslund

Frank Jooss | Jasmin Seidel

Frederic Michel & Matteo Scrimali | Chris Sterbling

Frederik Ehmke | Gemma McGowan

Georg Lenhardt | Nicole Volz

Gerwin Eisenhauer | Uli Zrenner-Wolkenstein

James Stewart | Paweł Mielko

Jan Pfennig | Sascha Höcker

Janosch Rathmer | Simon von der Gathen

Joahannes Scheer | Alexander Penndorf

Jonny König | Kadir Caliskan

Kai Tschierschky | Peter Leukhardt

Kerim Lechner | Marie Idlin

Kludia Kovács | Norbert Radó

Matthias Ambros | Michael Zoehling

Max Zimmer | Max Heiden

Miloš Meier | Nicola Bernad

Patrick Grün | Tom Row

Paul Seidel | Emma Kollmorgen

Philo Tsoungui | Joseph Strauch

Robert Gruss | Svenja Metzner

Roman Baumgartner | Roman Baumgartner

Sascha Madsen | Marco Sensche

Sebastian Lanser | Radek Dočekal

Sebastian Wyrobisch | Matthias Michael Maria Bedenk

Simon Gattringer | Henrik Bergerbusch

Simon Phillips | Marco Hammer

Simon Popp | Johannes Brugger

Stefan Günther-Martens | Jobst Meese

Tobias Schuler | Emanuel Oropesa

Wilhelm Belgart | Jan-Philipp Behr

Wolfram Kellner | Gabriel Köhler

TAMA Germany | Axel Winkler

Christian Bass

Hannes Grossmann

Jann Hillrichs

Jürgen Reil

Lucas Heiby

Mario Stübler



TAMA Drums distributed by

Roland Meinl Musikinstrumente GmbH & Co. KG  
Musik-Meinel-Str. 1 · 91468 Gutenstetten · Germany  
Tel. +49 (0) 9161 7880 · Fax. +49 (0) 9161 788 100  
[info@meinldistribution.eu](mailto:info@meinldistribution.eu)



**TAMA**<sup>®</sup>



 Tama Drums  Tama Official  officialtamadrums  @TAMAofficial

[www.tama.com](http://www.tama.com)

Actual product colors may not exactly be the same as the one shown on the catalog photos due to lighting and photo resolution. All specifications are subject to change without notice.

©2021 TAMA DRUMS All rights reserved. (M)